

1 2 3 4 5 6 7 8
 ALL DIMENSIONS IN MILLIMETRES
 REMOVE ALL SHARP EDGES

1118 8
 THIRD ANGLE PROJECTION
 DO NOT SCALE DRAWING

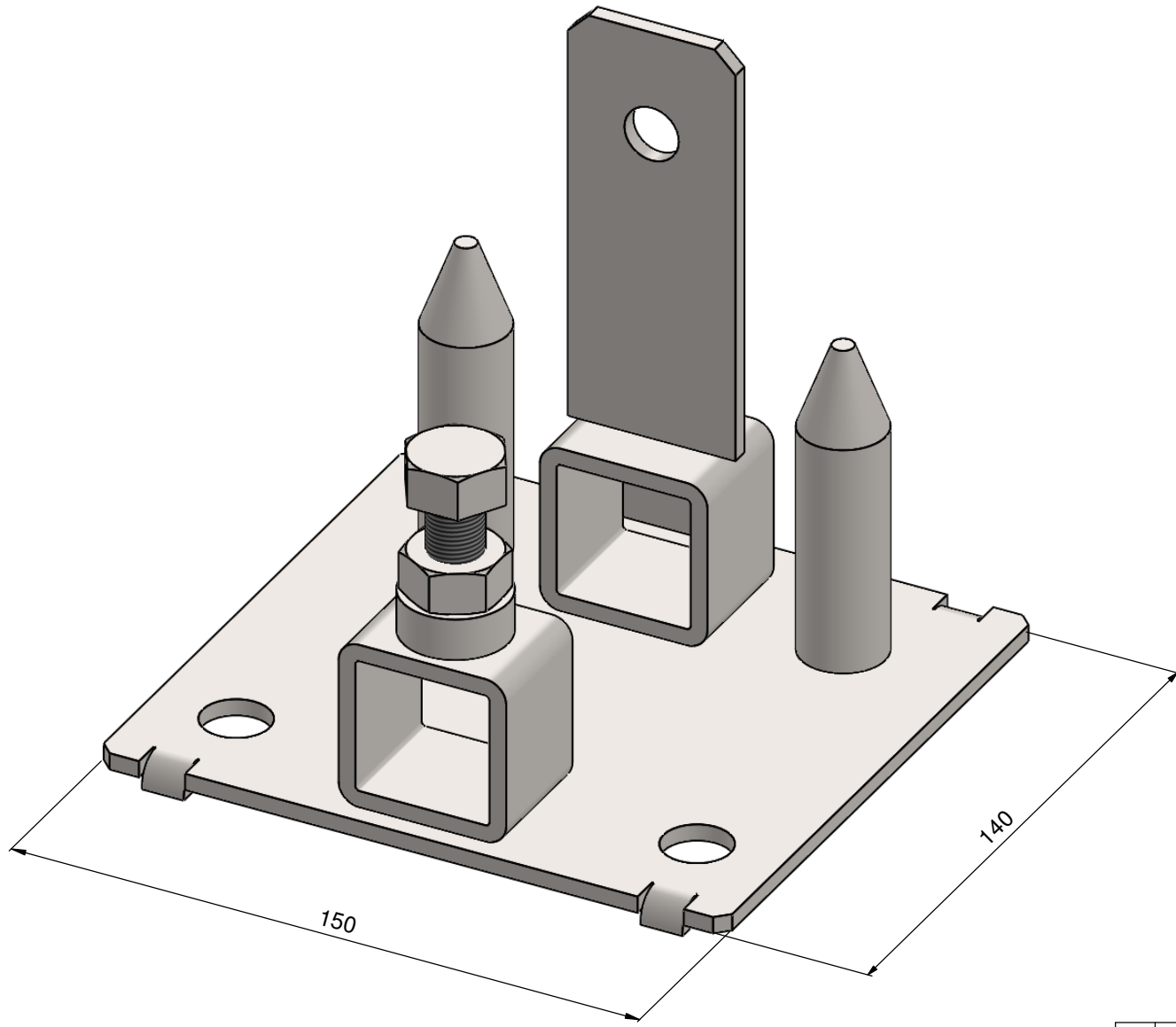

5	19/1/16	ISSUED FOR MANUFACTURE	GC		
4	4/2/15	ISSUED FOR MANUFACTURE	GC		
REV	DATE	DESCRIPTION	DRN	CHKD	APPR

TOLERANCES - UNLESS STATED OTHERWISE	
UNTOLERANCED DIMENSIONS	+/- 2mm
CUTTING LENGTHS	+/- 2mm
FABRICATION	
UP TO 300mm	+/- 1mm
UP TO 1000mm	+/- 2mm
1001mm & ABOVE	+/- 3mm
ANGULAR	+/- 1°
MACHINING	+/- 0.2mm
GAUGE	+/- 10%
WEIGHT	+/- 10% (DUE TO MATERIAL PROPERTIES & TOLERANCES)

TITLE: WINDBREAKER ZERO-TRIP FOOT			
NAME	SIGNATURE	DATE	MATERIAL:
G. CRICK		30/10/12	CARBON STEEL
CHK'D			
FINISH:			
ZINC PLATED			
WEIGHT: 1.4 Kg			

	GENERATION HIRE & SALE SCAFFOLDING & ACCESS	
	Drw / Stockcode No. 16552096	Revision 5

THE COMPANY RETAIN THE RIGHT TO PERIODICALLY ALTER INFORMATION WITHIN THIS DRAWING SHEET AND WILL ATTEMPT TO NOTIFY ALL PARTIES CONCERNED OF ANY CHANGES AND THE INFORMATION ON THIS SHEET SHOULD NOT BE REPRODUCED WITHOUT THEIR WRITTEN CONSENT.