

ALL DIMENSIONS IN MILLIMETRES  
REMOVE ALL SHARP EDGES

1117 8  
THIRD ANGLE PROJECTION  
DO NOT SCALE DRAWING

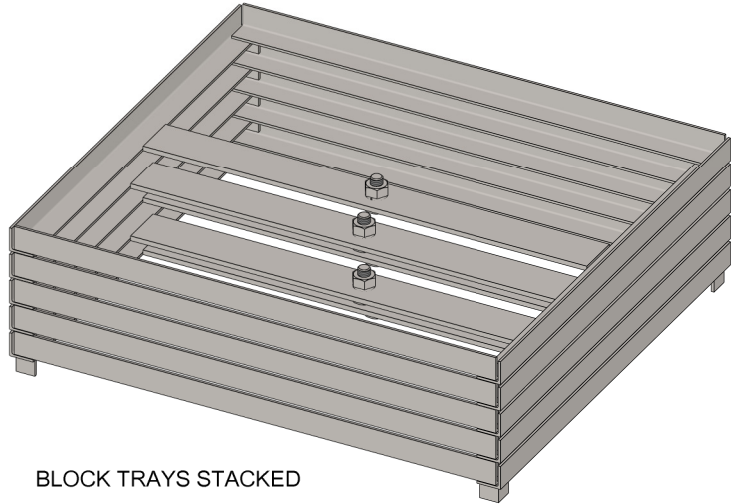

BLOCK TRAYS STACKED

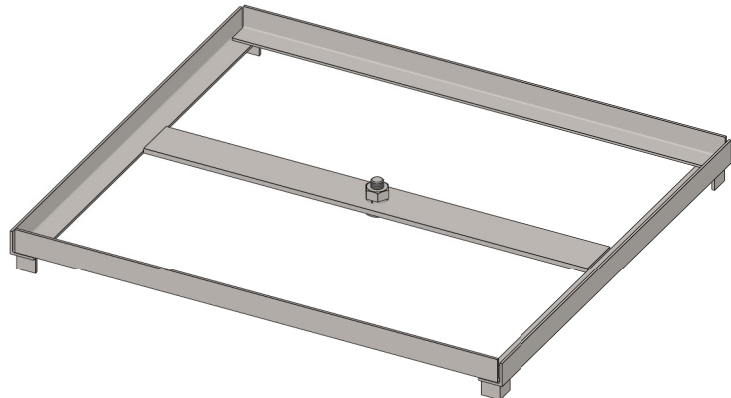
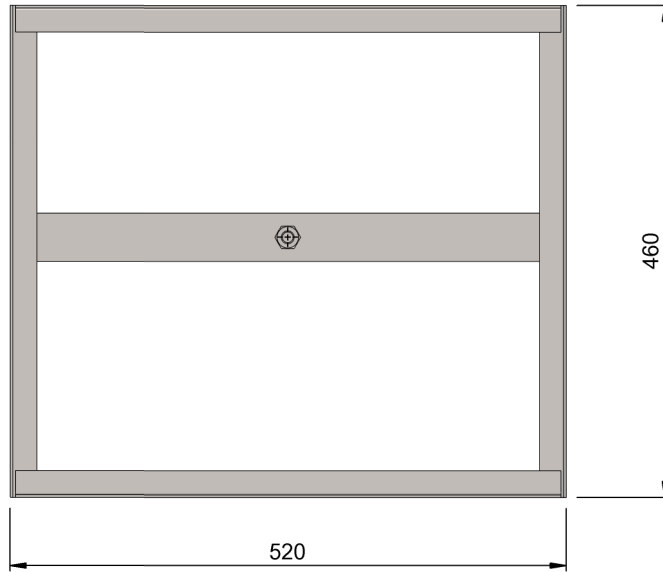

7	3/7/19	ISSUED FOR MANUFACTURE	GC	.	.
6	3/7/19	ISSUED FOR MANUFACTURE	GC	.	.
REV	DATE	DESCRIPTION	DRN	CHKD	APPR

TOLERANCES - UNLESS STATED OTHERWISE		
FABRICATION	UP TO 300mm	+/- 1mm
	UP TO 1000mm	+/- 2mm
	1001mm & ABOVE	+/- 3mm
	ANGULAR	+/- 1°
MACHINING	+/- 0.2mm	
GAUGE	+/- 10%	
WEIGHT	+/- 10% (DUE TO MATERIAL PROPERTIES & TOLERANCES)	

TITLE: <b>HOARDING BLOCK TRAY REAR</b>			
NAME	SIGNATURE	DATE	MATERIAL:
G. CRICK		9/11/7	<b>CARBON STEEL GRADE S275</b>
CHK'D			
FINISH: <b>ELECTRO-PLATED</b>			

	<b>GENERATION HIRE &amp; SALE</b> SCAFFOLDING & ACCESS	
	Drw / Stockcode No. <b>16551530</b>	Revision <b>7</b>

THE COMPANY RETAIN THE RIGHT TO PERIODICALLY ALTER INFORMATION WITHIN THIS DRAWING SHEET AND WILL ATTEMPT TO NOTIFY ALL PARTIES CONCERNED OF ANY CHANGES AND THE INFORMATION ON THIS SHEET SHOULD NOT BE REPRODUCED WITHOUT THEIR WRITTEN CONSENT.