

Hire and Sale Branches Freephone:
0800 779 7113

Birmingham (West)

Trinity Street Off Tat Bank Road,
Oldbury, West Midlands, B69 4LA
T: 0121 544 3355 F: 0121 544 3131
E: birmingham@generationuk.co.uk

Birmingham (East) G

87-93 Amington Road, Birmingham,
West Midlands, B25 8ET
T: 0121 706 0000 F: 0121 706 9832
E: birminghameast@generationuk.co.uk

Bristol

Unit 7, 12-16 Foundry Lane, Fishponds,
Bristol, B55 7UE
T: 0117 972 4550 F: 0117 972 4502
E: bristol@generationuk.co.uk

Cardiff

Martin Road, Tremorfa Industrial Estate
Cardiff, CF24 5SD
T: 029 2046 3835 F: 029 2046 3246
E: cardiff@generationuk.co.uk

Edinburgh

4 Westerton Road,
East Mains Industrial Estate, Broxburn,
West Lothian, EH52 5AU
T: 01506 863 864 F: 01506 863 916
E: edinburgh@generationuk.co.uk

Frimley (West London)

22-30 Sturt Road, Frimley Green
Camberley, GU16 6HY
T: 01252 838 696 F: 01252 837 614
E: frimley@generationuk.co.uk

Gateshead G

Stoneygate Lane, Abbotsford Road,
Felling, Gateshead, NE10 0EX
T: 0191 469 7504 F: 0191 469 8237
E: gateshead@generationuk.co.uk

Glasgow

Duchess Road, Rutherglen
Glasgow, G73 1AU
T: 0141 647 6969 F: 0141 647 5851
E: glasgow@generationuk.co.uk

Grays G

Europa Business Park, Magnet Road,
Grays, Essex, RM20 4DB
T: 01375 312 120 F: 01375 386 844
E: grays@generationuk.co.uk

Leeds

Unit 2 Ledger Park, Haigh Park Road,
Stourton, Leeds LS10 1RT
T: 0113 277 8822 F: 0113 277 7545
E: leeds@generationuk.co.uk

London (East)

Unit H, Hangman's Wood Ind Park,
Stifford Road, South Ockendon,
Essex, RM15 6RL
T: 020 7473 6056 F: 01708 858 493
E: london@generationuk.co.uk

Newcastle

Forward House, Portobello Road
Portobello Industrial Estate, Birtley,
Tyne and Wear, DH3 2SN
T: 0191 492 1190 F: 0191 411 1148
E: newcastle@generationuk.co.uk

Northampton

Kingsfield Way, Dallington,
Northampton, NN5 7QN
T: 01604 580 444 F: 01604 580 487
E: northampton@generationuk.co.uk

Salsburgh G

Duntilland Road, Shotts, Salsburgh,
North Lanarkshire, ML7 4NZ
T: 01698 870 200 F: 01698 870 159
E: salsburgh@generationuk.co.uk

Stockport

Unit 4 Vauxhall Industrial Estate,
Greg Street, Reddish,
Stockport, SK5 7BR
T: 0161 477 0131 F: 0161 477 7618
E: stockport@generationuk.co.uk

West Thurrock (East London)

4 Riverside Ind. Park, Oliver Road,
West Thurrock, RM20 3ED
T: 020 7476 4760 F: 020 7476 3157
E: westthurrock@generationuk.co.uk

Widnes G

Pitt Street, West Bank, Widnes,
Cheshire, WAB 0TG
T: 0151 420 3331 F: 0151 495 2298
E: widnes@generationuk.co.uk

Altrad Training Services

Unit 20B Greens Industrial Park,
Calder Vale Road, Wakefield, WF1 5PH
T: 01924 370 640 F: 01924 377 530
Freephone: 0800 587 5224
E: training@altraduk.co.uk

Generation Export

Trinity Street, Off Tat Bank Road
Oldbury, West Midlands, B69 4LA
T: +44 (0) 121 543 2964
E: export@generationuk.co.uk

Generation UK Head Office

Trinity Street, Off Tat Bank Road
Oldbury, West Midlands, B69 4LA
T: 0121 543 2950 F: 0121 543 2953
E: enquiries@generationuk.co.uk

GENERATION

Trestle Handrail System Erection Guide

LW/06.19

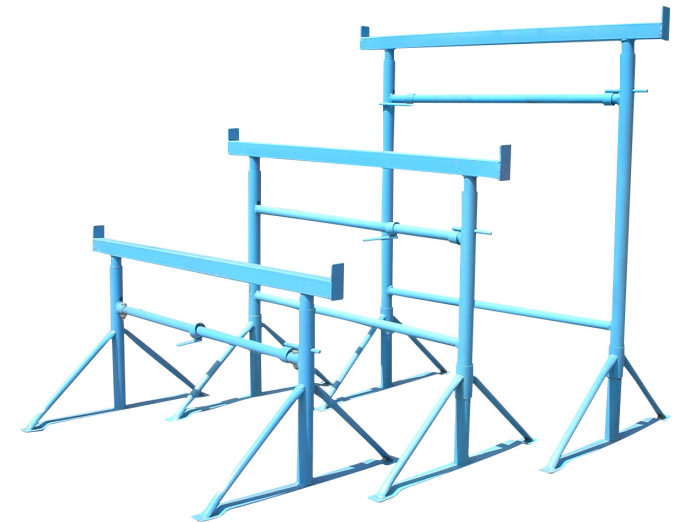

G GROUNDWORKS



GENERATION UK Ltd
Generation Head Office, Trinity Street, Off Tat Bank Road, Oldbury, West Midlands, B69 4LA - United Kingdom
Tel. 0121 543 2950 - Fax. 0121 543 2953 - enquiries@generationuk.co.uk
www.generationuk.co.uk



Generation UK Ltd
Trinity Street, Off Tat Bank Road,
Oldbury, West Midlands, B69 4LA
Tel: 0800 779 7113
Email: enquiries@generationuk.co.uk
www.generationuk.co.uk

Trestle Handrail System

For the erection and fitting of a Trestle Handrail System to Standard Builders Trestles.

Checklist

- This system should only be constructed on a firm level base.
- Always inspect components prior to use.
- Ensure risk assessments and method statements are completed and adhered to.
- Supervision should be provided that is appropriate to the work situation and skills of the team.
- Safe working load of builders trestles should not be exceeded.
- SWL 4.0kN/m² (based on 4 board wide platform and trestles at 1.2m maximum centres).
- PPE should be worn during the erection and dismantling process.

FREephone
0800 779 7113



Introduction

The Generation Trestle Handrail System has been designed to meet the requirements of the Working at Height Regulations 2005 and to be used with regular size 1, 2 and 3 builders trestles.

Fully tested to BS EN 13374:2004 (Class A) Temporary Edge Protections Systems.

Ensure scaffold boards conform to BS2482:2009 (Table A1).

Four Basic Components

Trestle handrail
Panel Code: 359006

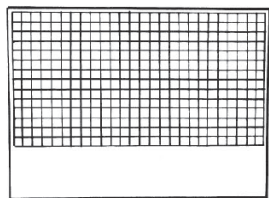

Trestle handrail post
Code: 359005

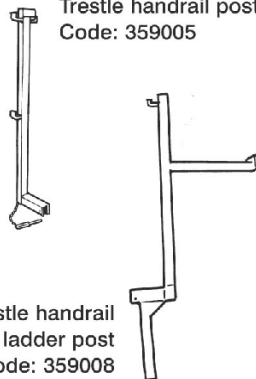

Trestle handrail
stabiliser
Code: 359007

Trestle handrail
ladder post
Code: 359008

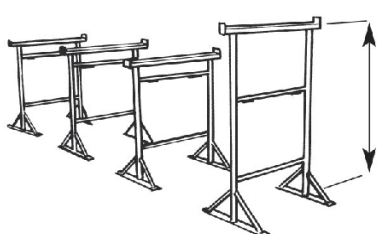

1 Set out trestles and adjust to required height. Board support should not exceed 1.2m span. Boards should over sail no less than 50mm and no more than 150mm as per TG20.

Lift trestle leg and **2** place stabiliser underneath. Secure with pin and spring clip.

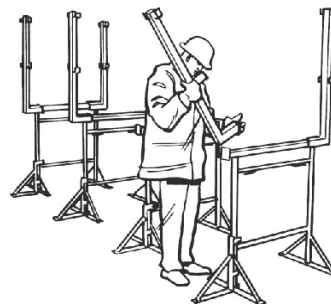
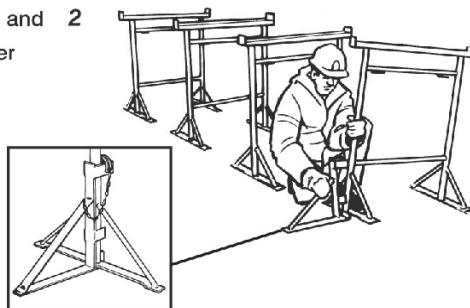

3 Attach posts to trestle top rungs and secure with pin and spring clip. Both end trestles **MUST** have 2 posts attached.

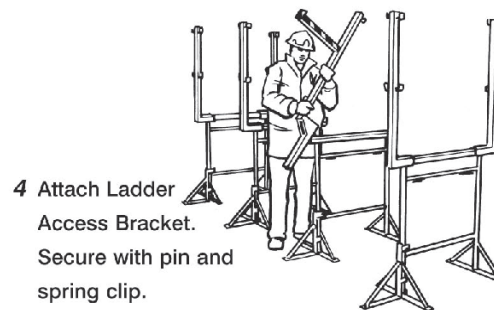

4 Attach Ladder Access Bracket. Secure with pin and spring clip.

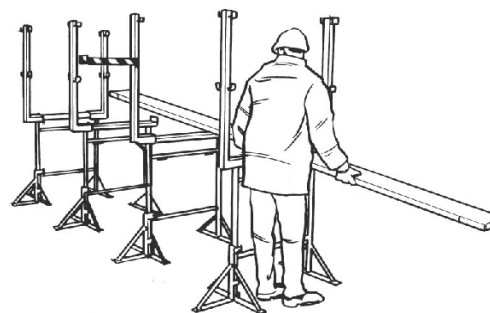

5 Place 4 scaffold boards along the trestles, leaving a gap between the facing posts and the boards to accommodate the panels.



6 Fit the two end panels by hooking each panel over the 4 brackets on the posts. The panel should protrude out over the stabiliser to prevent trip.

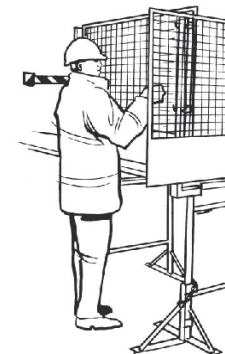

7 Hook on the front facing panels, leaving a panel space next to the ladder bracket.



8 Correctly lean and tie an appropriate ladder against the ladder bracket. Hook on and overlap the remaining panel. To access platform, simply unhook and slide the panel to the side. Hook back into position once on the platform.

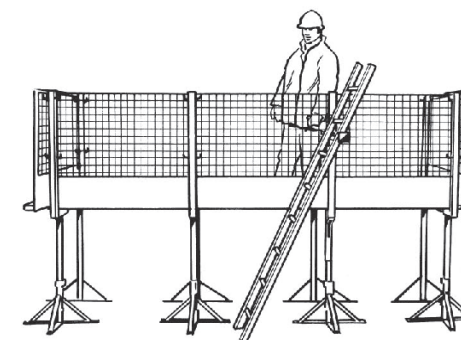

The Generation Trestle Handrail System has been designed and tested for use with trestles supplied by Generation Hire & Sale

The Generation Trestle Handrail System has been designed to provide handrailing, debris guard and toe board for trestles in normal use. The recommended maximum height is 1.568m to allow access to work 3.068m high. It is not intended to provide an alternative to conventional scaffolding where it is required by risk assessment.