

GENERATION

Span Tower User Guide

LW/05.19



Generation UK Ltd
Trinity Street, Off Tat Bank Road,
Oldbury, West Midlands, B69 4LA
Tel: 0800 779 7113
Email: enquiries@generationuk.co.uk
www.generationuk.co.uk

Working at Height

The Work at Height Regulations 2005 Section 5 requires that mobile tower operators are competent, or if being trained, are being supervised by a competent person. Competence can be evidenced by the production of a PASMA Standard Course ID Card.

The operator must also have access on site to the Manufacturer's Instruction Manual (MIM) appropriate to the particular tower specification.

We recommend that components from other manufacturers are not used, as to do so may prejudice the British Standard Certification and/or the manufacturers Product and Public Liability Insurance.

Persons holding a current PASMA Standard Training Certificate are considered to be competent to:

- Assemble, Use, Reposition & Disassemble Mobile Access Towers
- Complete Inspections and Reports (see page 29 to 30).

NB

- Damaged or incorrect components shall not be used.
- This MIM is only suitable for Generation Access Span towers with anti-slip rungs at 250mm Ctrs MAT designation EN1004-3-8/12-XXXX.

SPAN TOWERS WITH RUNGS AT 250mm Ctrs
(6ft, 8ft & 10ft Double & Single Width)
MAT Designation EN1004-3-8/12-XXXX
Kitemark Licence Number KM07045 – BS EN 1004 2004
Quality Management System Assessed to BS EN ISO 9001
Instruction Manual for Mobile Access Towers (MATs) for heights of 2.5m to 12m
Indoors (not exposed to wind) and 2.5m to 8m outdoors (may be exposed to wind) To BS EN 1298 – (IM) – EN

Disclaimer

Whilst Generation (UK) Ltd has taken every reasonable effort to ensure the information contained within this publication is correct and complete at the time of printing, you should be aware that there will be periodical changes and Generation (UK) Ltd does not accept any liability for any inconvenience, loss or damage caused as a result of any inaccuracy or omission within this publication.

Copyright

No unauthorised reproduction of any images, text or other matter contained herein is permitted. All rights are expressly reserved, including copyright, design right, moral and patent rights (where applicable). We reserve the right to take legal action in respect of any infringement of said rights.

Contents

Components	4-5
Even Platform Height MATs - Assembly Procedure	5-8
Single Width MATs & Odd Platform Height MATs - Assembly Procedure	8-13
Dismantling Procedure.....	14
Management of Health and Safety & Work at Height Regulations	15 -16
Additional Requirements of BS EN 1298.....	17 -23
6ft D/W Span Tower	24
8ft D/W Span Tower	25
10ft D/W Span Tower.....	26
6ft S/W Span tower	27
8ft S/W Span Tower	28
10ft S/W Span Tower	29
Inspection Checklist	30
Aluminium Tower Inspection Report.....	31
Requirements for the Inspection and Reporting on MATs.....	32
Positioning of Stabilisers	33
Use of Wall Struts.....	34
Altrad Training Services	35

COMPONENTS

1. Locking Castor (Trail No-Trail)
2. Adjustable Leg
3. Horizontal / Guardrail Brace
4. Diagonal Brace
5. Standard Platform
6. Hatch Door Platform
7. 1m D/W Frame (250mm Rung Crs)
8. 2m D/W Frame (250mm Rung Crs)
9. 1m S/W Frame (250mm Rung Crs)
10. 2m S/W Frame (250mm Rung Crs)
11. Double Width Toeboard (One Piece)
12. Single Width Toeboard (One Piece)
13. Telescopic Stabiliser
14. Wall Strut with Noduled Rubber Foot and 2 off Swivel Couplers

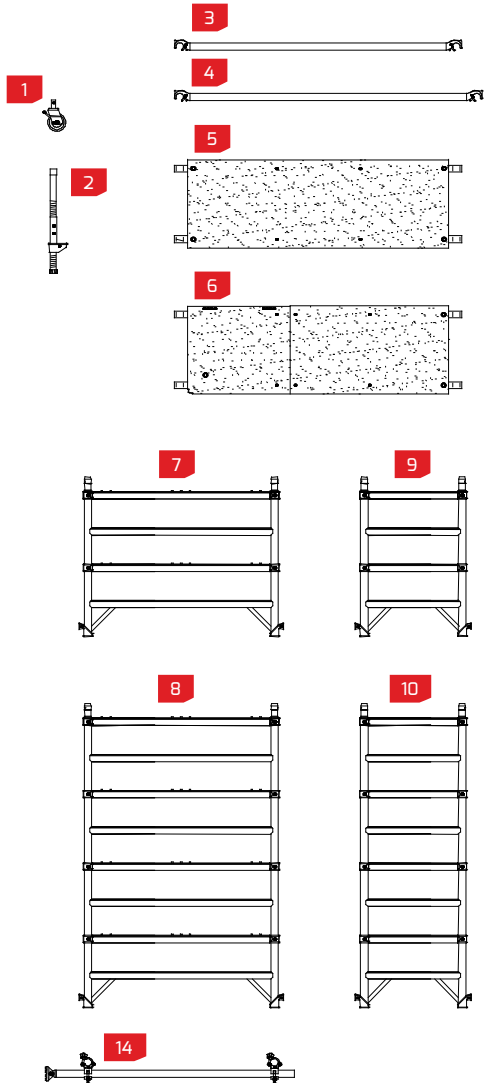

- Check that the delivery note matches what you have received, and that you have received the MIM appropriate to the MAT you have ordered.
- Check that the quantities of components match the breakdown of the MAT you have ordered. The correct component breakdown is shown on pages 23 to 28.
- Check that the components are serviceable (see pages 21 and 22, inspection and testing) and compatible (all from the same manufacturer and for the same type of MAT).

CHECK THE RISK ASSESSMENT DOCUMENT

N.B. Whilst the illustrations are of a 6ft long MAT, the same instructions apply to 8ft and 10ft long MATs and whilst double width frames are shown in the majority of illustrations the instructions also detail the assembly of single width MAT's. The only difference is that single width MATs have 2 diagonal braces per 2m lift as opposed to double width MATs, which have 4 diagonal braces.

Remember when fitting any platform board or brace always ensure that the hook at the other end is fitted in the corresponding position on the other side of the MAT.

IF YOU REQUIRE AN ODD METRE FINAL PLATFORM HEIGHT MAT i.e. 3.25M, 5.25M, 7.25M, GO TO STEP 1 (ODD) ON PAGE 8.

IF YOU REQUIRE AN EVEN METRE FINAL PLATFORM HEIGHT MAT i.e. 2.25M, 4.25M, 6.25M, START WITH STEP 1 (EVEN) BELOW.

EVEN PLATFORM HEIGHT MAT'S - ASSEMBLY PROCEDURE

Primed frame collar

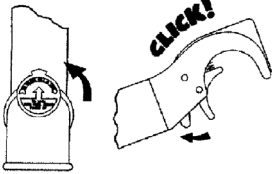

Primed hook

Step 1 (Even)

Prime all frame collars, the arrow on the plastic cap will point towards the other end of the frame.

Prime all hooks on braces by pressing the triggers (If the brace has just been removed from a parking tube it will be primed.).

Braces are attached by pressing a primed hook onto the frame and are detached by pressing the trigger and lifting it away.

N.B. After having fitted a frame onto a frame check that the frame collar pins have engaged by attempting to lift the upper frame.

Start with two 1 metre frames

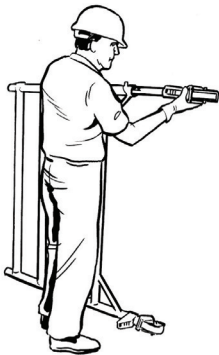

Step 2 (Even)

Fit the castors into the adjustable legs, and then fit the adjustable legs (with the castors fitted) into the verticals of the frame (The red cap on the frame collars should be temporarily lifted as you insert the leg).

Step 3 (Even)

Turn the adjustable legs until the frame collar location pins engage.

N.B. Ensure that each pair of leg trigger hoods are on the same side of the frame as eventually they must be inboard of the MAT.



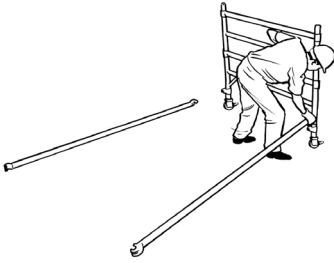

Step 4 (Even)

Whilst ensuring that the leg trigger hoods are both inboard, fit two horizontal braces on the verticals of one frame just above the frame collars, with the open part of the hook facing outboard.

N.B. These braces are the first on and the last off.

The frame will now stand independently.

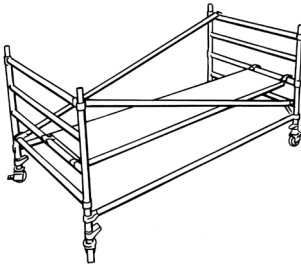

Step 5 (Even)

Fit the other ends of the horizontal braces to the other frame, and ensure that all 4 leg trigger hoods are inboard. Lock castor wheels by depressing the brake levers.

Place a platform as a temporary platform on the second rung from the bottom with the outboard hooks in the third position from the verticals using the central location pins to ensure that the base of the unit is "square"



Step 6 (Even)

After unlocking the castors by lifting the brake levers, position the MAT and level it by fine adjustment "A" or q by quick release trigger "B" and ensure the MAT is vertical in both planes.

N.B. At least one leg should remain fully retracted.

CHECK THAT ALL CASTORS ARE RELOCKED.

Step 7 (Even)

Where a Generation Access Tower ID Tag is being used to identify the tower for the purposes of Inspection and Reporting this should now be located onto one of the frame spigots.

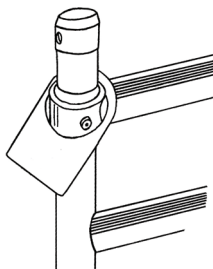

Care should be taken when fitting further frames to ensure that the ID Tag does not become trapped between the frame collar and the T piece preventing the spigot connecting the frames from fully engaging.

Step 8 (Even)

Fit two 2m frames on top of the two 1m frames. Check that the frame collar pins have engaged by trying to lift the frame (**DO THIS EACH TIME YOU FIT A FRAME**).

IF YOU ARE ASSEMBLING A SINGLE WIDTH TOWER REFER TO INSTRUCTIONS IN STEP 1 ON PAGE 7, OTHERWISE...

Fit four diagonal braces exactly as per the illustration. The first two diagonal braces form an "X" configuration on opposite sides of the MAT with the lower hooks on the first rung hard against the verticals. The hooks at the other end of these braces fit onto the fourth rung from the bottom.

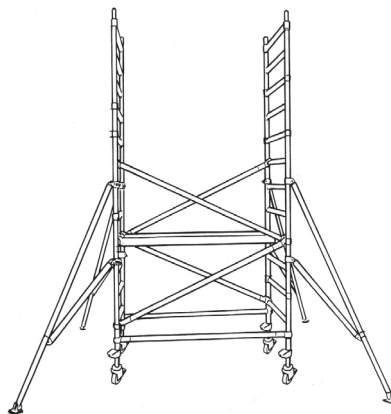

The second two diagonal braces form an "X" configuration on opposite sides of the tower with the lower hooks fitting onto the fourth rung from the bottom with the hooks locating in the 2nd position from the verticals.

The hooks at the other end of these braces locate onto the 7th rung from the bottom.

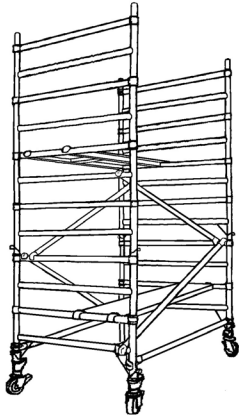

Step 9 (Even)

While standing on the temporary platform fit a hatch door platform on the 8th rung from the bottom on the opposite side of the tower to the temporary platform with the outboard hooks in the 3rd position from the verticals.

The remaining instructions are the same for both the odd and even platform height MAT's, go to Step No 11 (Odd & Even) on page 11.

SINGLE WIDTH MAT'S - ASSEMBLY PROCEDURE

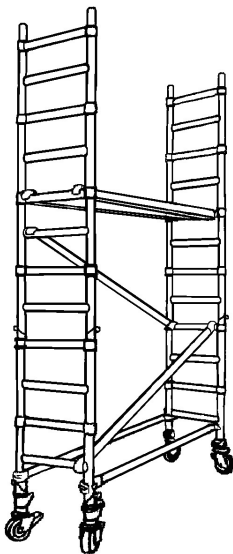

Step 1 (Single Width)

If assembling a Single Width MAT fit the first diagonal brace hard against the verticals between the first and fourth rung from the bottom as per the illustration.

Fit the second diagonal brace between the fourth and seventh rungs from the bottom on the opposite side of the MAT with the hooks hard against the verticals. All subsequent diagonal braces will be fitted after the guardrail braces and will therefore locate onto the 2nd position from the verticals.

Apart from the working platform only consisting of one platform and that only two diagonal braces are used where four are used on the Double Width MAT all of the Double Width instructions will apply to a Single Width MAT.

IF BUILDING AN EVEN HEIGHT MAT RETURN TO STEP 8 (EVEN) ON PAGE 6

IF BUILDING AN ODD HEIGHT MAT RETURN TO STEP 6 (ODD) ON PAGE 9

SINGLE WIDTH & ODD PLATFORM HEIGHT MAT'S - ASSEMBLY PROCEDURE

Step 1 (Odd)

Prime all frame collars, the arrow on the plastic cap will point towards the other end of the frame.

Prime all hooks on braces by pressing the triggers (If the brace has just been removed from a parking tube it will be primed.).

Braces are attached by pressing a primed hook onto the frame and are detached by pressing the trigger and lifting it away.

N.B. After having fitted a frame onto a frame check that the frame collar pins have engaged by attempting to lift the upper frame.

START WITH 2 METRE FRAMES

Step 2 (Odd)

Fit the castors into the adjustable legs, and then fit the adjustable legs (with the castors fitted) into the verticals of the frame (The red cap on the frame collars should be temporarily lifted as you insert the leg).

Step 3 (Odd)

Turn the adjustable legs until the frame collar location pins engage.

N.B. Ensure that each pair of leg trigger hoods are on the same side of the frame as eventually they must be inboard of the MAT.

Primed frame collar

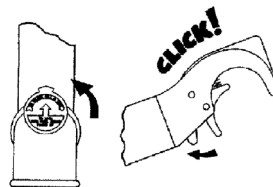

Primed hook

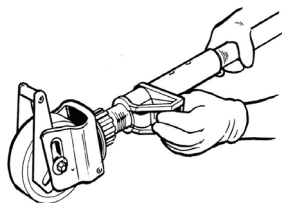

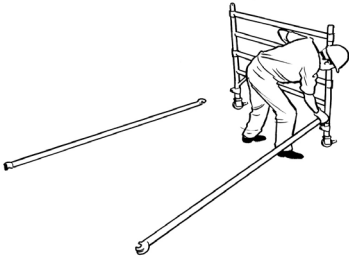

Step 4 (Odd)

Whilst ensuring that the leg trigger hoods are both inboard, fit two horizontal braces on the verticals of one frame just above the frame collars, with the open part of the hook facing outboard.

N.B. These braces are the first on and the last off.

The frame will now stand independently.

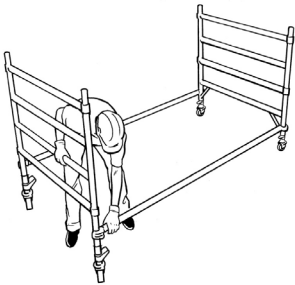

Step 5 (Odd)

Fit the other ends of the horizontal braces to the other frame, and ensure that all 4 leg trigger hoods are inboard. Lock castor wheels by depressing the brake levers.

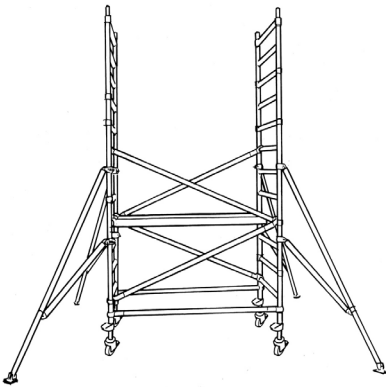

Step 6 (Odd)

IF YOU ARE ASSEMBLING A SINGLE WIDTH TOWER REFER TO INSTRUCTIONS IN STEP 1 ON PAGE 8

Fit two diagonal braces exactly as per the illustration forming an "X" configuration on opposite sides of the MAT with the lower hooks on the first rung hard against the verticals. The hooks at the other end of these braces fit onto the fourth rung from the bottom.

Place a platform as a temporary platform on the fourth rung from the bottom with the outboard hooks in the fourth position from the verticals using the location pins to ensure that the base of the unit is "square" (The inboard platform hooks will locate on the

Step 7 (Odd)

After unlocking the castors by lifting the brake levers, position the MAT and level it by fine adjustment "A" or by quick release trigger "B" and ensure the MAT is vertical and horizontal in both planes.

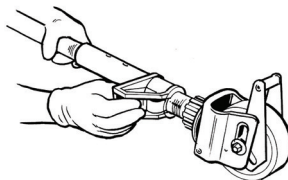

N.B. At least one leg should remain fully retracted.

CHECK THAT ALL CASTORS ARE RELOCKED.

Step 8 (Odd)

Fit two diagonal braces exactly as per the illustration forming an "X" configuration on opposite sides of the MAT with the lower hooks on the fourth rung in the second position from the verticals. The hooks at the other end of these braces fit onto the seventh rung from the bottom.

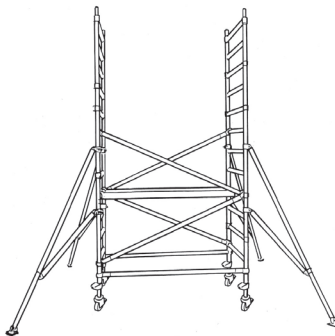

Step 9 (Odd)

Where a Generation Access Tower ID Tag is being used to identify the tower for the purposes of Inspection and Reporting this should now be located onto one of the frame spigots.

Care should be taken when fitting further frames to ensure that the ID Tag does not become trapped between the frame collar and the T piece preventing the spigot connecting the frames from fully engaging.

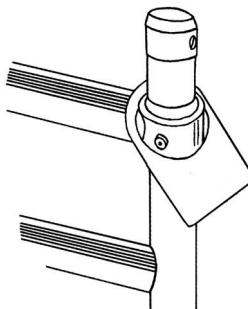



Step 10 (Odd)

Fit two more 2m frames on top of the MAT. Fit two diagonal braces exactly as per the illustration forming "X" configuration on opposite sides of the MAT with the lower hooks on the eighth from the bottom hard against the verticals. The hooks at the other end of these braces fit onto the eleventh rung from the bottom.

Place a hatch door platform on the twelfth rung from the bottom on the opposite side of the tower to the temporary platform with the outboard hooks in the third position from the verticals.

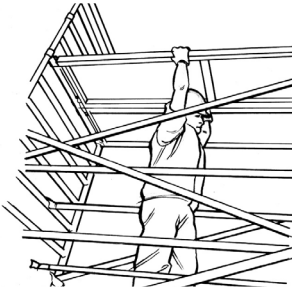

Step 11 (Odd & Even)

Fit the stabilisers to the MAT, as per the plan view shown. To obtain the maximum extension of the stabilisers the lower arm should be as near to horizontal as possible.

USE THE MAXIMUM OUTREACH AND FORM A PERFECT SQUARE. SEE PAGE 32 WHEN WORKING AGAINST A WALL, IF USING WALL STRUTS SEE PAGE 33



If you are using the large telescopic stabilisers, delay fitting until the MAT has been built to an overall height of 4m.

Step 12 (Odd & Even)

Whilst standing halfway through the top hatch door platform fit four guardrail braces on the rungs at 1m and 500mm above the platform on both sides. The outboard guardrail braces should fit in the second position from the vertical and the inboard braces immediately above the inboard platform edge.

The position of the lower brace should prevent the hatch being left open.

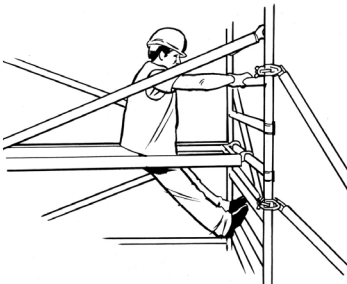

IF THE TOP PLATFORM IS ALREADY AT THE FINAL PLATFORM HEIGHT THEN GO TO THE COMPLETION INSTRUCTIONS STARTING WITH STEP 1 (COMPLETION) ON PAGE 12, OTHERWISE CONTINUE TO STEP 13 (ODD & EVEN).

Step 13 (Odd & Even)

Standing on the topmost platform (you are contained within the guardrails) Fit two more 2m frames on top of the MAT.

Fit four diagonal braces exactly as per the illustration with each pair of braces forming "X" configuration on opposite sides of the MAT with the hooks hard against the verticals.

N.B. You will note that the position of the diagonal braces is different to those fitted in the first (bottom) 2m lift of the MAT.

In the second and subsequent 2m lifts of the MAT the hooks of all diagonal braces should be hard against the verticals with the hooks spaced one rung apart on each side of the MAT.

Place a hatchdoor platform on the fifth rung down from the top directly above the existing top platform. The outboard platform hooks should locate in the third position from the verticals and the hatch should be at the same end as the hatch in the platform beneath.

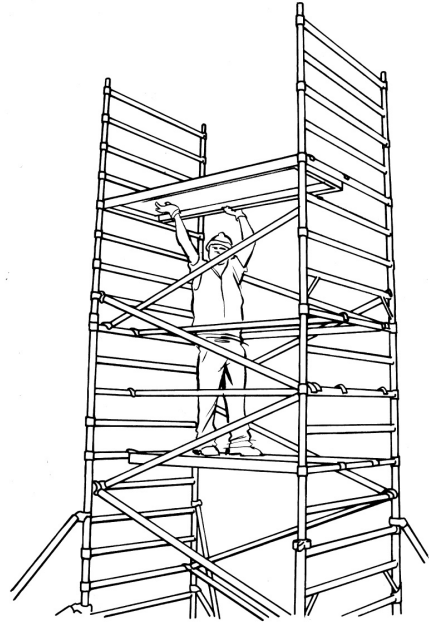

REPEAT STEP 12 (ODD & EVEN) AND STEP 13 (ODD & EVEN) UNTIL THE FINAL PLATFORM HEIGHT IS REACHED.

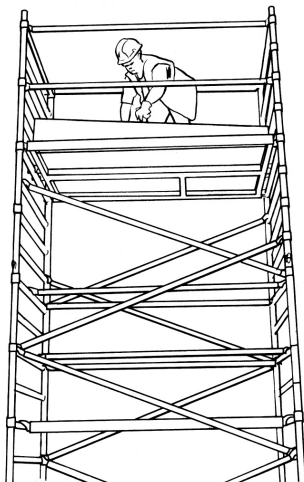

Step 1 (Completion)

If only a single top working platform is required fit a single width toeboard.

If a double width platform is required then, working from the lower platform level, reposition the top hatch door platform to allow a standard platform to be fitted alongside it. Ensure that the inboard edges of the platform decks abut at the middle of the rung.

Return to the position where you were halfway through the top hatch door platform and reposition all the guardrail braces so that they are in the first position adjacent to the tower verticals. Fit a double width toeboard.

N.B. Toeboards are required on all working platforms or where materials are stored.

DISASSEMBLY PROCEDURE

This is simply the reverse procedure to the assembly. With the exception that before descending to a point halfway through the hatch door platform you must disengage the four guardrail brace hooks at the end furthest from the hatch door leaving the primed hooks resting on the rungs of the frame.

When removing braces, having detached the hook at one end of the brace from the MAT keep the hook in close proximity to its original position whilst disengaging the second hook.

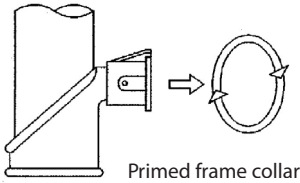

To disengage frames, the Red plastic caps of the frame collars should be pulled and turned clockwise a quarter turn, this will retract the frame collar locking pin.

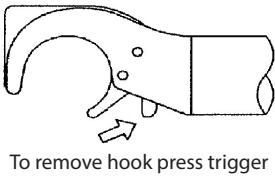

Braces are detached by pressing the trigger, a light spring is actuated to push the brace away from the frame.

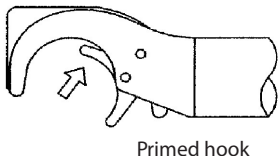

The segment may be pressed to prevent accidental re-engagement, except when disassembling the handrails referred to in the disassembly instructions above.

MANAGEMENT OF HEALTH AND SAFETY & WORK AT HEIGHT REGULATIONS

Regulation 3 of the Management of Health & Safety Regulations requires employers and self-employed persons to carry out a risk assessment, covering both workers and others who may be affected by their work or business. The assessment should address the effect of their undertaking, work activities and the condition of the premises.

Users of mobile access towers must be familiar with, and comply with, the requirements of the Work at Height Regulations 2005. The following responsibilities are included under this regulation:

- To take account of risk assessments under Regulation 3 of the Management of Health and Safety at Work Regulations.
- Not to carry out work at height where it is reasonably practicable to carry out the work safely otherwise than at height.
- That where work is carried out at height, take suitable and sufficient measures to prevent, so far as is reasonably practicable, any person falling a distance liable to cause a personal injury.
- That work at height is properly planned, appropriately supervised and carried out in a manner which is so far as reasonably practicable safe. The planning extends to and includes the selection of the work equipment. Emergencies and rescue should also be considered during planning.
- To ensure that work at height is only carried out when the weather conditions do not jeopardise the health or safety of the persons involved in the work.
- To select work equipment for work at height that has characteristics, including dimensions, appropriate to the nature of the work to be performed and the foreseeable loadings; and allow passage without risk; and is in all other respects the most suitable work equipment.
- To ensure that no person engages in any activity, including organisation, planning and supervision in relation to work at height or work equipment for use in such work unless they are competent to do so or, if being trained, is being supervised by a competent person.

Generation Access Span Towers when erected and used in accordance with the information contained in this Erection Guide will provide the user with collective protection during the erection use and dismantling of the equipment as required by the Work at Height Regulations.

ADDITIONAL SAFETY POINTS

- A** Mobile access and working towers may only be erected and dismantled by persons familiar with these instructions for erection and use.
- B** Damaged components shall not be used.
- C** Only original components in accordance with the data supplied by the manufacturer shall be used
- D** The ground on which the tower is to be moved shall be capable of supporting the weight of the structure.
- E** It is not permissible to move the tower with any materials or person(s) on it.
- F** Towers shall only be moved manually and only on firm level ground which is free from obstacles. Normal walking speed shall not be exceeded during location.
- G** Before use, check using the data supplied by the supplier, that the tower has been erected correctly and is standing perpendicularly.
- H** It is not permissible to attach and use hoisting arrangements on towers unless specifically provided for by design.
- I** We consider the height of the tower to be the height of the topmost rung minus 1m.
- J** It is not permissible to attach bridging between a tower and a building.
- K** Before use check that necessary precautions against accidental rolling away have been taken, e.g. by applying locking brakes or by using base plates.
- L** It is not permissible to gain access to or descend from the working platform other than by the intended access system
- M** It is forbidden to jump onto platforms.
- N** Towers used outdoors shall, whenever possible, be secured to a building or other structure.



ADDITIONAL REQUIREMENTS OF BS EN 1298

BS EN 1298 - (IM) - EN For Mobile Access and Working Towers (MATs)

Manufactured to BS EN 1004:2004 which applies to MATs of heights from 2.5M to 12M used indoors (not exposed to wind conditions) or 2.5M to 8M outdoors (may be exposed to wind conditions).

This Instruction Manual (IM) for MATs is prepared in accordance with BS EN 1298:1996, which gives rules and guidelines for its preparation and is in accordance with BS EN 1004:2004.

A MAT is not intended as a staintower to provide access to other structures.

A MAT may not be extended in height by the use of ladders or other devices, to extend the tower use more MAT equipment.

The persons assembling, using, repositioning or disassembling the MAT must have access to this MIM on site at that time. They should also be familiar with the contents of the PASMA Code of Practice. The Work at Height Regulations 2005 requires the operator be competent, or, if being trained, be under the supervision of a competent person. A MAT operator may be considered to be competent by virtue of training by a recognised organisation.

General Information

- Access to the working platform is by climbing the frame rungs on the inside of the tower. It should be noted that to permit such access the rungs are spaced 250mm centres and the top section of each rung has an anti-slip surface.
- The scaffold is made and tested to Class 3, in accordance with BS EN 1004:2004. The net designed load of various configurations of MAT is shown in the breakdown schedule. The designed load of individual platforms is 250kg evenly distributed. Any number of platforms may be loaded, provided the designed platform loading of 250kg, and the total MAX designed loading of the tower, shown in the breakdown schedule, are not exceeded.
- The breakdown of the individual components required for various configurations is shown in the break down schedule.
- The MAT should not be used, or moved, in wind speeds exceeding 17.2 m.p.h. (Beaufort scale 4); this is indicated by leaves on the trees rustling and light debris, such as leaves and paper being blown about. If this speed is exceeded free standing MAT's should be dismantled or secured. If the wind speed reaches 25 m.p.h., this is indicated when twigs and small branches are broken from trees, and walking is difficult, the MAT should be tied into a rigid structure. If the wind speed is likely to reach 40 m.p.h., this is indicated when large branches of trees move, telephone wires begin to whistle and umbrellas are difficult to control, the MAT should be dismantled.
- The MAT should be tied into a rigid structure if left unattended (refer to the Instruction Manual on Tying in Mobile Access Towers to Adjacent Buildings or structures).

Identification

The IM shows how the MAT should be erected and dismantled (pages 4 – 13).

The breakdown schedules (pages 23 - 28) shows the individual components needed to erect a specific height of tower with the net designed load of the MAT after the self weight of the components have been deducted.

Erection and Dismantling

A minimum of two operators is required to erect or dismantle a MAT in excess of 2M high. They shall have a rope of suitable specification to raise and lower components used in upper sections, alternatively they may be passed by hand with other operatives standing on intermediate platforms. The breakdown schedule lists the individual component parts, their weights, and the quantities of these parts needed for the erection of the MAT to a specified height.

The location of the MAT shall be checked to prevent hazards during assembly, disassembly, repositioning and use, with respect to:-

- A** Ground conditions, and must be capable of supporting the weight of the structure.
- B** Level and slope.
- C** Obstructions (ground and overhead).
- D** Wind conditions (current and potential).

Stability

Be warned that horizontal and vertical loads can contribute to the overturning of a MAT; horizontal forces such as pushing on a drill for example should not exceed 20kg.

Care must be taken when moving MATs, the information detailed on page 19 must be followed.

Wind forces can be magnified by the tunnelling effect of open ended buildings and unclad buildings.

When left unattended or used outdoors it is prudent to tie MATs to an adjacent fixed structure in accordance with the Instruction Manual "Tying in Mobile Access Towers to Adjacent Buildings or Structures".

Ties should ideally be at height intervals of 3M (the maximum vertical distance between ties is 4m). Each tie level should connect to the MAT with a horizontal tube at each end of the MAT fixed to both verticals of each frame, close to a joint using swivel or 90° couplers (compatible with the 50.8mm O/D MAT tube).

The other ends of the tubes must be securely fixed to the fixed structure as shown in Instruction Manual "Tying in Mobile Access Towers to Adjacent Buildings or Structures".

When a MAT is sited adjacent to a wall or rigid structure pairs of wall struts may be used to limit the movement of the MAT towards the wall or structure. Information on the use of wall struts is shown on page 33.

Stabilisers, outriggers and ballast must always be fitted when specified.

Use

Before each use of the MAT, check the following points:-

- A** The MAT is still vertical with castors locked.
- B** The structure assembly as per the MIM has not been altered.
- C** No environmental changes have affected the tower (snow, wind, ice etc.); if so, correct as necessary before use.

Under no circumstances should MATs have their platform height increased by use of ladders, boxes etc. Access to or descent from, the working platform must only be by the means intended by the manufacturer, users must not jump on platforms.

Tools and materials should be lifted to the platform by the use of ropes. If the items cannot be lifted within the footprint of the tower itself, they may be lifted close to the outside of the tower, but within the footprint of the stabilisers or outriggers where fitted. Care must be exercised to prevent overturning, and that the maximum designed load is not exceeded. Hoisting arrangements may not be attached to a MAT unless specifically provided for by design.

The castors are locked by depressing the brake pedal downwards and unlocked by lifting the brake pedal upwards.

Stabilisers, outriggers and ballast are only to be used as directed by the MAT manufacturer. Where ballast is used it should not be liquid or granular in form.

All necessary parts, auxiliary tools and safety equipment (rope, personal safety equipment, spirit level etc.) for erecting the MAT shall be available on site before work commences.

Inspection & Reporting

The Work at Height Regulations 2005 require an inspection of a MAT under the circumstances detailed below. To assist you an inspection checklist is shown on page 29.

- A** Before being taken into use after assembly or alteration.
- B** At suitable intervals not exceeding 7 days.
- C** After the occurrence of any exceptional circumstances which are liable to jeopardise the safety of the tower.

Where it is possible for someone to fall 2m or more the Work at Height Regulations also require that a report be produced of each inspection detailing the particulars set out on page 30. The report shall be completed by the end of the working period that the inspection was made.

The regulations further require that the report, or copy thereof, be submitted to the person on whose behalf the inspection was carried out within 24 hours of the completion of the inspection.

Check that the MAT is Vertical

The MAT must be vertical in both planes within an inclination of 1%. A spirit level should be used to check both vertical and horizontal alignment.

NB: Check both planes i.e. the long side and the short side.

Stabilisers and Outriggers

These shall be fitted with the couplers on the stabiliser locating onto the verticals of the base frames of the MAT. The lower stabiliser arm should be as close to horizontal as possible to maximise the "outreach".

Where outriggers are used the hooks on the outriggers should locate onto the verticals of the MAT base frames positioned immediately under the T pieces on the verticals. The outriggers should be triangulated with a suitable brace to prevent movement.

When using stabilisers or outriggers the stability of the MAT should be maximised with the four points of contact (stabiliser feet or outrigger castors) forming a perfect square.

Moving and repositioning MATs

Towers are limited to the following maximum heights when being moved.

Double Width Span Towers

Tower without stabilisers – maximum height 3.25m

Tower with telescopic stabilisers (103011) – maximum height 4.25m

Tower with large telescopic stabilisers (103077) – maximum height 4.25m

Single Width Span Towers

Tower without stabilisers – maximum height 2.25m

Tower with telescopic stabilisers (103011) – maximum height 4.25m

Tower with large telescopic stabilisers (103077) – maximum height 4.25m



Towers that are in excess of the above heights will have to be partially dismantled to reduce the height of the tower to within the above limits.

When moving a MAT the castors should be unlocked and the stabiliser feet lifted 25mm above the ground, by moving the position of the stabiliser couplers.

The MAT should only be moved manually at no more than walking speed, by the application of effort to the base of the MAT on firm level ground which is free of obstacles (including overhead), when repositioned, the castors should be re-locked and the stabilisers repositioned.

To adjust the height of the adjustable leg, squeeze the trigger mechanism towards the top of the trigger housing. The leg can then be adjusted in increments of 3.2mm, infinite adjustment is achieved by turning the castellated ring at the bottom of the adjustable leg.

To check the effective support of the outrigger or stabiliser, ensure that the castors or stabiliser feet are firmly in contact with the ground.

A MAT should never be moved with men or materials on it.

A MAT is not designed to be lifted or suspended.



Inspection care and maintenance

The following check list should be followed prior to equipment being made available for use:-

- 1** All components should be inspected to ensure that they are free of all foreign material.
- 2** All MAT components should be inspected visually for signs of damage, particular attention being paid to the following:-
 - A. Spigots should be straight and in line with the axis of the column tube:- check alignment from the front and side.
 - B. Frames, braces, stabilisers, outriggers, platforms, stairways and ladders:- check for distortion or damage.
 - C. Castings and welds:- check for fractures.
 - D. Location pins:- check none are damaged or missing.
 - E. Pull rings, telescopic stabiliser pins, interlock pins or collar caps:- check none are damaged or missing.
- 3** The following MAT components should be tested physically as shown:-
 - A. The castor wheel should be rotated and the moving parts oiled if necessary, the brake should be operated and should prevent rotation of the wheel. When checking "trail/no trail" castors, the operation of the brake will move the castor wheel directly under the frame vertical and will simultaneously prevent rotation and trailing; check that this happens and that the braking is effective. The spring loaded-device in the spigot should locate firmly in the adjustable leg and prevent accidental displacement.
 - B. The adjustable leg should be operated to ensure free adjustment and oiled if necessary, and it should also be checked visually to ensure it is straight and the thread is undamaged and clean. A castor should be fitted to the adjustable leg and the adjustable leg should be located into a frame collar to ensure that it can be retained correctly by the frame collar.
 - C. All hooks, with or without mechanism, should be tested with a piece of undamaged tube to ensure the correct operation of the mechanism and to confirm that the hook is not deformed. Particular attention should be paid to the platform board hooks.
 - D. All frame collar mechanisms should be checked with a spare spigot set in a "T" piece and oiled if necessary.
 - E. All spigots should be checked with a frame collar set in a short piece of tube.
 - F. Coupler type fittings on stabilisers should be tested on an undamaged piece of tube to ensure their correct operation. The telescopic legs should be checked for free operation and oiled if necessary.
 - G. All platform decks should be tested to ensure that the rivets are secure. When hinged, hinges and hatch catches should be operated to ensure correct operation.
 - H. One piece folding toeboards should be tested by fitting them on a board or boards placed on the floor. Particular attention should be paid to the hinges and the rivets joining the aluminium to the plywood.
 - I. Four piece toeboards should be tested by fitting them on a low-level MAT. Particular attention should be paid to the security of the aluminium corner brackets.

When any item is found to be defective it should be immediately taken out of service and quarantined prior to arrangements being made for it to be replaced or repaired by the original manufacturer to ensure the integrity of its original quality control manufacturing procedures. If beyond economic repair it should be destroyed.

Before using the checked equipment, ensure by reference to the appropriate MIM and component breakdown list, that not only the correct quantities are issued, but all components are compatible, are from the same manufacturer and are appropriate for that particular MAT. Particular attention should be paid to braces, the full description of which should be found on the identification label.

Handling, Transport and Storage

The life of aluminium alloy towers will be increased if proper care is taken of them during handling, erection, transportation and storage. Before storage all components should be cleaned. Any concrete or corrosive substance should be removed.

Proper stacking will reduce any damage, and will make identification of the components easier to re-issue.

Similarly, during transportation equipment should be properly stacked on vehicles. Space can be saved by systematically placing braces, platforms, stairways etc. In available space within vertically stacked frames.



6FT DOUBLE WIDTH SPAN TOWER

(250MM RUNG SPACING) with intermedite platforms at 2m increments

Platform Height	5" Castor	Adjustable Leg	2m D/W 8R Span Frame	1m D/W 4R Span Frame	6' Span Diagonal Brace	6' Span Horizontal Brace	6' Standard Platform	6' Small H/D Platform	6' D/W Folding Toeboard	Telescopic Stabiliser	Large Telescopic Stabiliser	Tower Self Weight	Maximum Permitted Load On Tower**
2.25m	7" 5"	4	4	2	2	4	6	1	1	1		113 kg	637 kg
3.25m	10" 8"	4	4	4		6	6	1	1	1		129 kg	621 kg
The maximum platform height without stabilisers is 3.25m, above this height attach the appropriate size of stabiliser in accordance with the tower instruction manual.													
4.25m	13" 11"	4	4	4	2	8	10	1	2	1	4	191 kg	559 kg
5.25m	17" 3"	4	4	6		10	10	1	2	1	4	207 kg	543 kg
6.25m	20" 6"	4	4	6	2	12	14	1	3	1	4	248 kg	502 kg
7.25m	23" 9"	4	4	8		14	14	1	3	1	4	265 kg	485 kg
8.25m	27" 1"	4	4	8	2	16	18	1	4	1	4	324 kg	426 kg
The maximum freestanding platform height for outdoor use is 8.25m, above this height the tower must be tied to a rigid structure in accordance with the tower instruction manual.													
9.25m	30" 4"	4	4	10		18	18	1	4	1	4	341 kg	409 kg
10.25m	33" 8"	4	4	10	2	20	22	1	5	1	4	381 kg	369 kg
11.25m	36" 11"	4	4	12		22	22	1	5	1	4	398 kg	352 kg
The maximum freestanding platform height for indoor use is 11.25m, above this height the tower must be tied to a rigid structure in accordance with the tower instruction manual.													
Component Part Number	103001	103002	103030	103040	103015	103006	103008	103017	103014	103011	103077	6ft DW Span V3	
Component Weight	2.4 kg	1.7 kg	12.2 kg	6.2 kg	2.4 kg	2.3 kg	13.1 kg	14.0 kg	8.9 kg	5.2 kg	10.0 kg		

** Subject to a maximum design load of 250kg per platform.

The following maximum heights apply to this tower when being moved or repositioned.

Tower without stabilisers - maximum height 3.25m

Tower with telescopic stabilisers (103011) - maximum height 4.25m

Tower with large telescopic stabilisers (103077) - maximum height 5.25m

Towers in excess of the above heights will have to be partially dismantled to reduce the height of the tower to within the above limits before moved.

Towers must only be moved in accordance with the information contained within this Instruction Manual



8FT DOUBLE WIDTH SPAN TOWER

(250MM RUNG SPACING) with intermedite platforms at 2m increments

Platform Height		5" Castor	Adjustable Leg	2m D/W 8R Span Frame	1m D/W 4R Span Frame	8' Span Diagonal Brace	8' Span Horizontal Brace	8' Standard Platform	8' Hatchdoor Platform	8' D/W Folding Toeboard	Telescopic Stabiliser	Large Telescopic Stabiliser	Tower Self Weight	Maximum Permitted Load On Tower**
2.25m	7' 5"	4	4	2	2	4	6	1	1	1			128 kg	622 kg
3.25m	10' 8"	4	4	4		6	6	1	1	1			145 kg	605 kg
The maximum platform height without stabilisers is 3.25m, above this height attach the appropriate size of stabiliser in accordance with the tower instruction manual.														
4.25m	13' 11"	4	4	4	2	8	10	1	2	1	4		213 kg	537 kg
5.25m	17' 3"	4	4	6		10	10	1	2	1	4		231 kg	520 kg
6.25m	20' 6"	4	4	6	2	12	14	1	3	1	4		278 kg	472 kg
7.25m	23' 9"	4	4	8		14	14	1	3	1	4		295 kg	455 kg
8.25m	27' 1"	4	4	8	2	16	18	1	4	1		4	362 kg	388 kg
The maximum freestanding platform height for outdoor use is 8.25m, above this height the tower must be tied to a rigid structure in accordance with the tower instruction manual.														
9.25m	30' 4"	4	4	10		18	18	1	4	1		4	379 kg	371 kg
10.25m	33' 8"	4	4	10	2	20	22	1	5	1		4	426 kg	324 kg
11.25m	36' 11"	4	4	12		22	22	1	5	1		4	444 kg	306 kg
The maximum freestanding platform height for indoor use is 11.25m, above this height the tower must be tied to a rigid structure in accordance with the tower instruction manual.														
Component Part Number	103001	103002	103030	103040	103031	103032	103033	103034	103036	103011	103077	8ft DW Span V2		
Component Weight	2.4 kg	1.7 kg	12.2 kg	6.2 kg	2.7 kg	2.6 kg	17.9 kg	19.1 kg	11.0 kg	5.2 kg	10.0 kg			

** Subject to a maximum design load of 250kg per platform.

The following maximum heights apply to this tower when being moved or repositioned.

Tower without stabilisers - maximum height 3.25m

Tower with telescopic stabilisers (103011) - maximum height 4.25m

Tower with large telescopic stabilisers (103077) - maximum height 5.25m

Towers in excess of the above heights will have to be partially dismantled to reduce the height of the tower to within the above limits before moved.

Towers must only be moved in accordance with the information contained within this Instruction Manual



10FT DOUBLE WIDTH SPAN TOWER

(250MM RUNG SPACING) with intermedite platforms at 2m increments

Platform Height		5" Castor	Adjustable Leg	2m D/W 8R Span Frame	1m D/W 4R Span Frame	10' Span Diagonal Brace	10' Span Horizontal Brace	10' Standard Platform	10' Hatchdoor Platform	10' D/W Folding Toeboard	Telescopic Stabiliser	Large Telescopic Stabiliser	Tower Self Weight	Maximum Permitted Load On Tower**
2.25m	7' 5"	4	4	2	2	4	6	1	1	1			211 kg	539 kg
3.25m	10' 8"	4	4	4		6	6	1	1	1			229 kg	521 kg
The maximum platform height without stabilisers is 3.25m, above this height attach the appropriate size of stabiliser in accordance with the tower instruction manual.														
4.25m	13' 11"	4	4	4	2	8	10	1	2	1	4		307 kg	443 kg
5.25m	17' 3"	4	4	6		10	10	1	2	1	4		325 kg	425 kg
6.25m	20' 6"	4	4	6	2	12	14	1	3	1	4		382 kg	368 kg
7.25m	23' 9"	4	4	8		14	14	1	3	1	4		400 kg	350 kg
8.25m	27' 1"	4	4	8	2	16	18	1	4	1		4	476 kg	274 kg
The maximum freestanding platform height for outdoor use is 8.25m, above this height the tower must be tied to a rigid structure in accordance with the tower instruction manual.														
9.25m	30' 4"	4	4	10		18	18	1	4	1		4	494 kg	256 kg
10.25m	33' 8"	4	4	10	2	20	22	1	5	1		4	551 kg	199 kg
11.25m	36' 11"	4	4	12		22	22	1	5	1		4	569 kg	181 kg
The maximum freestanding platform height for indoor use is 11.25m, above this height the tower must be tied to a rigid structure in accordance with the tower instruction manual.														
Component Part Number	103001	103002	103030	103040	103042	103041	103043	103044	103045	103011	103077	10ft DW Span V2		
Component Weight	2.4 kg	1.7 kg	12.2 kg	6.2 kg	3.1 kg	3.0 kg	21.8 kg	26.1 kg	79.7 kg	5.2 kg	10.0 kg			

** Subject to a maximum design load of 250kg per platform.

The following maximum heights apply to this tower when being moved or repositioned.

Tower without stabilisers - maximum height 3.25m

Tower with telescopic stabilisers (103011) - maximum height 4.25m

Tower with large telescopic stabilisers (103077) - maximum height 5.25m

Towers in excess of the above heights will have to be partially dismantled to reduce the height of the tower to within the above limits before moved.

Towers must only be moved in accordance with the information contained within this Instruction Manual



6FT SINGLE WIDTH SPAN TOWER

(250MM RUNG SPACING) with intermedite platforms at 2m increments

Platform Height		5" Castor	Adjustable Leg	2m S/W 8R Span Frame	1m S/W 4R Span Frame	6' Span Diagonal Brace	6' Span Horizontal Brace	6' Small H/D Platform	6' S/W Folding Toeboard	Telescopic Stabiliser	Large Telescopic Stabiliser	Tower Self Weight	Maximum Permitted Load On Tower**
2.25m	7' 5"	4	4	2	2	2	6	1	1			86 kg	664 kg
The maximum platform height without stabilisers is 3.25m, above this height attach the appropriate size of stabiliser in accordance with the tower instruction manual.													
3.25m	10' 8"	4	4	4		3	6	1	1	4		118 kg	632 kg
4.25m	13' 11"	4	4	4	2	4	10	2	1	4		154 kg	596 kg
5.25m	17' 3"	4	4	6		5	10	2	1	4		165 kg	585 kg
6.25m	20' 6"	4	4	6	2	6	14	3	1	4		201 kg	549 kg
7.25m	23' 9"	4	4	8		7	14	3	1		4	232 kg	519 kg
8.25m	27' 1"	4	4	8	2	8	18	4	1		4	267 kg	483 kg
The maximum freestanding platform height for outdoor use is 8.25m, above this height the tower must be tied to a rigid structure in accordance with the tower instruction manual.													
9.25m	30' 4"	4	4	10		9	18	4	1		4	279 kg	472 kg
10.25m	33' 8"	4	4	10	2	10	22	5	1		4	314 kg	436 kg
11.25m	36' 11"	4	4	12		11	22	5	1		4	326 kg	425 kg
The maximum freestanding platform height for indoor use is 11.25m, above this height the tower must be tied to a rigid structure in accordance with the tower instruction manual.													
Component Part Number	103001	103002	103038	103037	103015	103006	103008	103010	103011	103077	6ft SW Span V3		
Component Weight	2.4 kg	1.7 kg	9.5 kg	4.9 kg	2.4 kg	2.3 kg	14.0 kg	8.1 kg	5.2 kg	10.0 kg			

** Subject to a maximum design load of 250kg per platform.

The following maximum heights apply to this tower when being moved or repositioned.

Tower without stabilisers - maximum height 2.25m

Tower with telescopic stabilisers (103011) - maximum height 4.25m

Tower with large telescopic stabilisers (103077) - maximum height 5.25m

Towers in excess of the above heights will have to be partially dismantled to reduce the height of the tower to within the above limits before moved.

Towers must only be moved in accordance with the information contained within this Instruction Manual



8FT SINGLE WIDTH SPAN TOWER

(250MM RUNG SPACING) with intermedite platforms at 2m increments

Platform Height		5" Castor	Adjustable Leg	2m S/W 8R Span Frame	1m S/W 4R Span Frame	8' Span Diagonal Brace	8' Span Horizontal Brace	8' Hatchdoor Platform	8' S/W Folding Toeboard	Telescopic Stabiliser	Large Telescopic Stabiliser	Tower Self Weight	Maximum Permitted Load On Tower**
2.25m	7' 5"	4	4	2	2	2	6	1	1			95 kg	655 kg
The maximum platform height without stabilisers is 3.25m, above this height attach the appropriate size of stabiliser in accordance with the tower instruction manual.													
3.25m	10' 8"	4	4	4		3	6	1	1	4		128 kg	622 kg
4.25m	13' 11"	4	4	4	2	4	10	2	1	4		170 kg	580 kg
5.25m	17' 3"	4	4	6		5	10	2	1	4		182 kg	568 kg
6.25m	20' 6"	4	4	6	2	6	14	3	1	4		224 kg	526 kg
7.25m	23' 9"	4	4	8		7	14	3	1		4	255 kg	495 kg
8.25m	27' 1"	4	4	8	2	8	18	4	1		4	297 kg	453 kg
The maximum freestanding platform height for outdoor use is 8.25m, above this height the tower must be tied to a rigid structure in accordance with the tower instruction manual.													
9.25m	30' 4"	4	4	10		9	18	4	1		4	309 kg	441 kg
10.25m	33' 8"	4	4	10	2	10	22	5	1		4	351 kg	399 kg
11.25m	36' 11"	4	4	12		11	22	5	1		4	363 kg	387 kg
The maximum freestanding platform height for indoor use is 11.25m, above this height the tower must be tied to a rigid structure in accordance with the tower instruction manual.													
Component Part Number	103001	103002	103038	103037	103031	103032	103034	103052	103011	103077	8ft SW Span V2		
Component Weight	2.4 kg	1.7 kg	9.5 kg	4.9 kg	2.7 kg	2.6 kg	19.1 kg	9.8 kg	5.2 kg	10.0 kg			

** Subject to a maximum design load of 250kg per platform.

The following maximum heights apply to this tower when being moved or repositioned.

Tower without stabilisers - maximum height 2.25m

Tower with telescopic stabilisers (103011) - maximum height 4.25m

Tower with large telescopic stabilisers (103077) - maximum height 5.25m

Towers in excess of the above heights will have to be partially dismantled to reduce the height of the tower to within the above limits before moved.

Towers must only be moved in accordance with the information contained within this Instruction Manual



10FT SINGLE WIDTH SPAN TOWER

(250MM RUNG SPACING) with intermedite platforms at 2m increments

Platform Height	5" Castor	Adjustable Leg	2m S/W 8R Span Frame	1m S/W 4R Span Frame	10' Span Diagonal Brace	10' Span Horizontal Brace	10' Hatchdoor Platform	10' S/W Folding Toeboard	Telescopic Stabiliser	Large Telescopic Stabiliser	Tower Self Weight	Maximum Permitted Load On Tower**
2.25m 7' 5"	4	4	2	2	2	6	1	1			104 kg	646 kg
The maximum platform height without stabilisers is 3.25m, above this height attach the appropriate size of stabiliser in accordance with the tower instruction manual.												
3.25m 10' 8"	4	4	4		3	6	1	1	4		137 kg	613 kg
4.25m 13' 11"	4	4	4	2	4	10	2	1	4		185 kg	566 kg
5.25m 17' 3"	4	4	6		5	10	2	1	4		197 kg	553 kg
6.25m 20' 6"	4	4	6	2	6	14	3	1	4		244 kg	506 kg
7.25m 23' 9"	4	4	8		7	14	3	1		4	276 kg	474 kg
8.25m 27' 1"	4	4	8	2	8	18	4	1		4	323 kg	427 kg
The maximum freestanding platform height for outdoor use is 8.25m, above this height the tower must be tied to a rigid structure in accordance with the tower instruction manual.												
9.25m 30' 4"	4	4	10		9	18	4	1		4	336 kg	414 kg
10.25m 33' 8"	4	4	10	2	10	22	5	1		4	383 kg	367 kg
11.25m 36' 11"	4	4	12		11	22	5	1		4	395 kg	355 kg
The maximum freestanding platform height for indoor use is 11.25m, above this height the tower must be tied to a rigid structure in accordance with the tower instruction manual.												
Component Part Number	103001	103002	103038	103037	103041	103043	103044	103065	103011	103077	10ft SW Span V2	
Component Weight	2.4 kg	1.7 kg	9.5 kg	4.9 kg	3.1 kg	3.0 kg	22.6 kg	11.9 kg	5.2 kg	10.0 kg		

** Subject to a maximum design load of 250kg per platform.

The following maximum heights apply to this tower when being moved or repositioned.

Tower without stabilisers - maximum height 2.25m

Tower with telescopic stabilisers (103011) - maximum height 4.25m

Tower with large telescopic stabilisers (103077) - maximum height 5.25m

Towers in excess of the above heights will have to be partially dismantled to reduce the height of the tower to within the above limits before moved.

Towers must only be moved in accordance with the information contained within this Instruction Manual



INSPECTION CHECKLIST

Section 12 of the Work at Height Regulations 2005 requires that a mobile access towers be inspected by a competent person in accordance with the schedule below.

1. Before being taken into use after erection or alteration
2. At suitable intervals not to exceed 7 days.
3. After the occurrence of any exceptional circumstances which are liable to have jeopardised the safety of the tower.

It must be remembered that before the tower erected the components should have been checked for damage by the operative erecting the tower. Despite this the inspector should check the condition of the components as they progressively climb the tower with particular attention to cracked welds and obvious deformation.

If it is not possible for someone the fall 2m* or more then no report is required. If however it is possible for someone to fall 2m* or more then each inspection requires a report to be produced by the person undertaking the inspection by the end of the working period that the inspection was made.

The report (or a copy) shall be provided to the person on whose behalf the inspection was undertaken within 24 hours of completing the inspection.*

N.B. This does not necessarily mean a 2m platform height as the tower may be sited at the side of a pit, swimming pool or stairs that descend below the base of the tower.

Checklist from the ground.

1. Check the last official report on the tower that was required by section 12 of the Work at Height Regulations
2. Check that you have a copy of the current Manufacturers Instruction Manual (MIM) appropriate to the tower specification on site and that it has been read and understood
3. Check the risk assessment document
4. Check that no environmental changes have influenced the safe use of the tower
5. Check that where castors are fitted that the castor brakes have been applied
6. Check that the castors or baseplates fitted to the tower together with the rubber feet or castors fitted to any stabilisers or outriggers are in contact, with the ground, bearing their share of the weight of the tower and that the surface that they are on is firm and stable.
7. Where stabilisers are fitted check that the wing nuts on the coupler connections are fully tightened by the gloved hand
8. Check that the narrowest side of the footprint of the tower is sufficient to support the tower as a freestanding tower
9. Check that outriggers, where fitted, are correctly triangulated and braced in that position
10. Check that the tower is vertical in two planes
11. From the ground check that all components are in their correct position by reference to the MIM

Checklist climbing the tower progressively.

12. Check that where the tower identification plate is used it is sited on the top of the first frame.
13. Check that both ends of the horizontal braces, diagonal braces and platform boards (with wind clips fitted) are correctly located in their opposing positions.
14. Check that the mechanisms of the hooks have operated correctly.
15. Check that the platform hatches open towards the outboard side of the tower and that the position of the guardrail brace prevents them being left open.
16. Check that the interlock mechanisms joining the frame spigots to sockets are in position and are effective with the arrows on the red knobs pointing upwards.
17. Where the MIM indicates that the tower should be tied in, check the method of tying to ensure that it is adequate with the ties at the correct height and spacing.
18. Check toeboards are fitted to all working platforms and all platforms where tools, equipment or materials are to be stored or placed and that the toeboards do not prevent platform hatches opening freely.

Site Location..... Description of Tower.....

Time Date Tower ID plate No.....

Name..... Signature PASMA Cert No.....

Inspection report on a Mobile Access Tower as required by Regulation 12 of the Work at Height Regulations 2005. To be completed in duplicate.

Inspection records are required on any tower from which a person could fall 2m* or more.

* This does not necessarily mean a 2m platform height as the tower may be sited at the side of a pit, swimming pool or stairs that descend below the base of the tower.

1. Before being taken into use after erection or alteration
2. At suitable intervals not to exceed 7 days.
3. After the occurrence of any exceptional circumstances which are liable to have jeopardised the safety of the tower.

1 The name and address of the person for whom the inspection was carried out.

2 The location of the work equipment inspected

--

3 A description of the work equipment inspected

Cross Sectional Size	Platform Height
Manufactured by	Tower ID or Ref No

4 The date and time of the inspection

--

5 Details of any matter identified that could give rise to a risk to the health or safety of any person

6 Details of any action taken as a result of any matter identified in paragraph 5

7 Details of any further action considered necessary

8 Name and position of the person making the report

--

Inspectors Name Description Signature
 PASMA Std Course Cert. No Report Completed Date Time

The Inspection Report must be completed by the person who carried out the inspection by the end of the working period in which the inspection was made.

One copy of the report to be retained by inspecting signatory, one copy to be given (within 24 hours of the inspection) of the person on whose behalf the inspection was carried out.

Signature of the person for whom the inspection was carried out and receipt for report, or copy thereof

INSPECTION AND REPORTING OF MOBILE ACCESS TOWERS

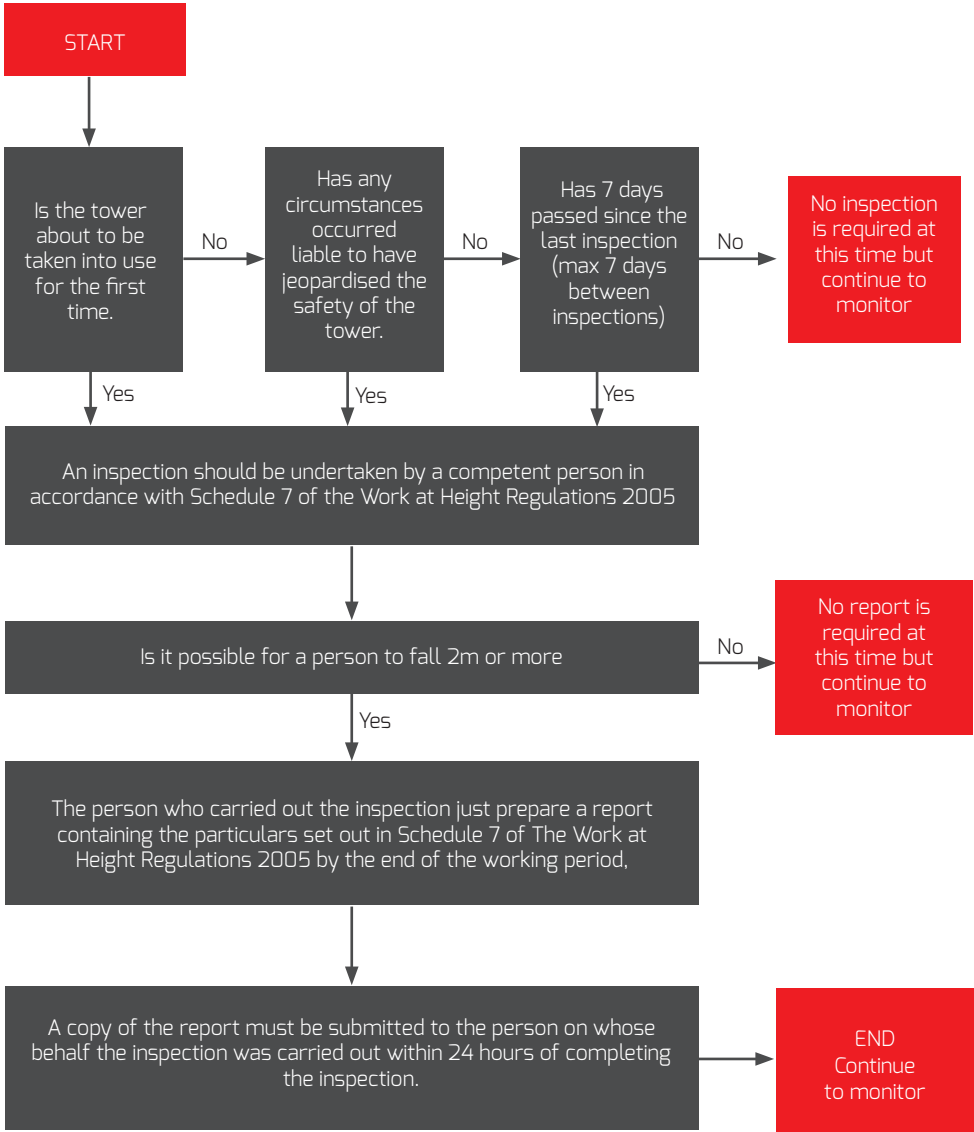

POSITIONING OF STABILISERS

The maximum free standing height of a MAT is obtained when the outriggers/stabilisers form a perfect square, but when sited against a wall the inboard outriggers/stabilisers should be sited parallel to the wall. Provided the wall is at least two thirds of the height of the tower the same stability is obtained.

The dashed line indicates the notional position of the inboard stabilisers (as if the wall was not present). These determine the position of the outboard stabilisers.

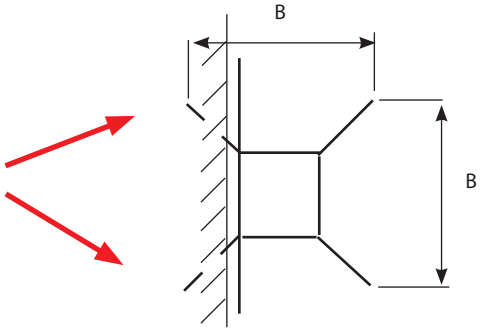

If the MAT is moved away from the wall the inboard outriggers/stabilisers should be progressively moved into a new position where the outriggers/stabilisers eventually form a perfect square.

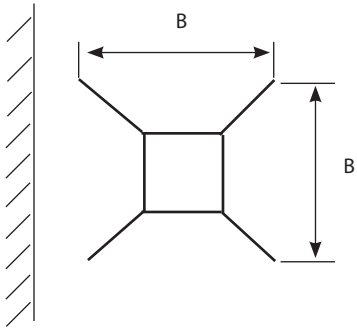
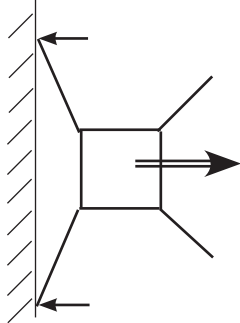

USE OF WALL STRUTS

(To be used in pairs at opposite ends of the tower).

When a tower is sited adjacent to a wall or rigid structure pairs of wall struts may be used to limit the movement of the tower towards the wall or structure. When using wall struts the following points should be noted.

Wall struts should only be fitted at levels equal to or higher than the topmost attachment point of the stabilisers or outriggers.

Each wall strut should be coupled to two verticals of the same frame of the tower with the couplers sited immediately above a frame rung.

The couplers used to connect the wall struts to the tower must be MAT type couplers.

Wall struts alone do not constitute a tie between the tower and the adjacent building or rigid structure. Unless additional ties are fitted in accordance with this instruction manual and the instruction manual for the tying in of towers, the tower must be considered to be free standing.



Generation Training Services are PASMA, IPAF, Ladder Association and CISRS accredited training providers for Mobile Access Towers, Low Level Access, Elevated Mobile Work Platforms (MEWPS), Ladders & Steps and Genlok System Scaffolding; and are able to provide all access related Health & Safety training.

Generation Training Services have a team of skilled instructors who can provide a wide range of access and work related training, which can be individually tailored to suit your own industry requirements. Generation has developed close links with other nationally accredited training organisations and can offer a Training Broker Service to our clients, providing access to hundreds of courses from one point of contact.

These include:

- CITB SMSTS/SSTS
- ITSSAR Forklift Truck Training Courses
- UKATA Asbestos Awareness
- NPORS Plant Operator Courses

Complete training packages can be tailored to suit your requirements.

For more details call:

0800 587 5224



Hire and Sale Branches Freephone:
0800 779 7113

Birmingham (West)

Trinity Street Off Tat Bank Road,
 Oldbury, West Midlands, B69 4LA
 T: 0121 544 3355 F: 0121 544 3131
 E: birmingham@generationuk.co.uk

Birmingham (East)

87-93 Amington Road, Birmingham,
 West Midlands, B25 8ET
 T: 0121 706 0000 F: 0121 706 9832
 E: birminghameast@generationuk.co.uk

Bristol

Unit 7, 12-16 Foundry Lane, Fishponds,
 Bristol, B55 7UE
 T: 0117 972 4550 F: 0117 972 4502
 E: bristol@generationuk.co.uk

Cardiff

Martin Road, Tremorfa Industrial Estate
 Cardiff, CF24 55D
 T: 029 2046 3835 F: 029 2046 3246
 E: cardiff@generationuk.co.uk

Edinburgh

4 Westerton Road,
 East Mains Industrial Estate, Broxburn,
 West Lothian, EH52 5AU
 T: 01506 863 864 F: 01506 863 916
 E: edinburgh@generationuk.co.uk

Frimley (West London)

22-30 Sturt Road, Frimley Green
 Camberley, GU16 6HY
 T: 01252 838 696 F: 01252 837 614
 E: frimley@generationuk.co.uk

Gateshead

Stonegate Lane, Abbotsford Road,
 Felling, Gateshead, NE10 0EX
 T: 0191 469 7504 F: 0191 469 8237
 E: gateshead@generationuk.co.uk

Glasgow

Duchess Road, Rutherglen
 Glasgow, G73 1AU
 T: 0141 647 6969 F: 0141 647 5851
 E: glasgow@generationuk.co.uk

Grays

Europa Business Park, Magnet Road,
 Grays, Essex, RM20 4DB
 T: 01375 312 120 F: 01375 386 844
 E: grays@generationuk.co.uk

Leeds

Unit 2 Ledger Park, Haigh Park Road,
 Stourton, Leeds LS10 1RT
 T: 0113 277 8822 F: 0113 277 7545
 E: leeds@generationuk.co.uk

London (East)

Unit H, Hangman's Wood Ind Park,
 Stifford Road, South Ockendon,
 Essex, RM15 6RL
 T: 020 7473 6056 F: 01708 858 493
 E: london@generationuk.co.uk

Newcastle

Forward House, Portobello Road
 Portobello Industrial Estate, Birtley,
 Tyne and Wear, DH3 2SN
 T: 0191 492 1190 F: 0191 411 1148
 E: newcastle@generationuk.co.uk

Northampton

Kingsfield Way, Dallington,
 Northampton, NN5 7QN
 T: 01604 580 444 F: 01604 580 487
 E: northampton@generationuk.co.uk

Salsburgh

Duntilland Road, Shotts, Salsburgh,
 North Lanarkshire, ML7 4NZ
 T: 01698 870 200 F: 01698 870 159
 E: salsburgh@generationuk.co.uk

Stockport

Unit 4 Vauxhall Industrial Estate,
 Greg Street, Reddish,
 Stockport, SK5 7BR
 T: 0161 477 0131 F: 0161 477 7618
 E: stockport@generationuk.co.uk

West Thurrock (East London)

4 Riverside Ind. Park, Oliver Road,
 West Thurrock, RM20 3ED
 T: 020 7476 4760 F: 020 7476 3157
 E: westthurrock@generationuk.co.uk

Widnes

Pitt Street, West Bank, Widnes,
 Cheshire, WA8 0TG
 T: 0151 420 3331 F: 0151 495 2298
 E: widnes@generationuk.co.uk

Altrad Training Services

Unit 20B Greens Industrial Park,
 Calder Vale Road, Wakefield, WF1 5PH
 T: 01924 370 640 F: 01924 377 530
 Freephone: 0800 587 5224
 E: training@altraduk.co.uk

Generation Export

Trinity Street, Off Tat Bank Road
 Oldbury, West Midlands, B69 4LA
 T: +44 (0) 121 543 2964
 E: export@generationuk.co.uk

Generation UK Head Office

Trinity Street, Off Tat Bank Road
 Oldbury, West Midlands, B69 4LA
 T: 0121 543 2950 F: 0121 543 2953
 E: enquiries@generationuk.co.uk

 GROUNDWORKS



GENERATION UK Ltd
 Generation Head Office, Trinity Street, Off Tat Bank Road, Oldbury, West Midlands, B69 4LA - United Kingdom
 Tel. 0121 543 2950 - Fax. 0121 543 2953 - enquiries@generationuk.co.uk
www.generationuk.co.uk