

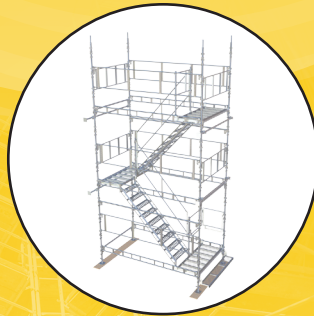

GENERATION STAIR TOWER

USER GUIDE



Hire and Sale • Access • Export • Training Services

GENERATION SCAFFOLDING AND ACCESS SUPPORT FOR CONSTRUCTION AND INDUSTRY

***Generation is the largest UK supplier of access, scaffolding, safety and training products.
Our customer promise is to deliver the:***

BEST QUALITY

We work in partnership with our suppliers to ensure we deliver consistent quality every time. We guarantee that our hire and sales products will meet and conform or exceed all statutory requirements and not let you down.

BEST AVAILABILITY

We have the largest available UK inventory of scaffolding, access and safety products. Our branch network and delivery fleet will ensure that we deliver what you need, when you need it.

BEST PARTNERSHIP

We provide a full range of engineering, design and business services to partner and work with our customers. Talk to us today about how we can help you to grow your business.

BEST PRICES

We use our position as the largest UK supplier of scaffolding products to negotiate the best rates for you. We guarantee you will get the best value products and service when you hire or buy from us.

Disclaimer

Whilst Generation (UK) Ltd has taken every reasonable effort to ensure the information contained within this publication is correct and complete at the time of printing, you should be aware that there will be periodical changes and Generation (UK) Ltd does not accept any liability for any inconvenience, loss or damage caused as a result of any inaccuracy or omission within this publication.

Copyright

No unauthorised reproduction of any images, text or other matter contained herein is permitted. All rights are expressly reserved, including copyright, design right, moral and patent rights (where applicable). We reserve the right to take legal action in respect of any infringement of said rights.

Contents Page

Introduction	4
Compliance	5
Stair Tower Basic Information	6
Stair Tower Erection Notes	7
Safety Information	8
General Site Safety	9
Principle Components	10-12
Safe Erection Sequence	13-20
Toe Board Arrangements	21
Standard Leg Make-ups	22
Repair and Maintenance	23
Safe Working Loads	24
Maximum Heights	25-27
Bracing and Tying In	27
Crane Handling of Towers	28
Rescue Plan	29
Training Services	30
Generation Stair Tower Training	31

The Generation Business

HIRE AND SALE

Are the UK's largest suppliers of scaffolding, access and safety products. Through a nationwide network of branches, a full hire and sale service is provided to the Construction and Industrial sectors.

ACCESS

Specialist branches supplying a full range of modular aluminium access towers, low level access and safe access solutions.

TRAINING SERVICES

A full range of PASMA, IPAF, CISRS, CITB, ITSSAR and Health and Safety training courses are available.

EXPORT

From scaffolding ancillaries to full sea freight containers of scaffolding, our export division provides a cost effective procurement solution.

Introduction

Generation Stair Tower has been designed specifically to provide a safe, stable, site staircase enabling personnel to gain access to the working level swiftly and efficiently. Independently to other scaffolds or system scaffolds, towers can be erected with full access landings, double handrails and non-slip stair units in steel. The use of Generation staircases on site improves safety, replaces ladders and allows multiple numbers of personnel to climb safely to their work place at one time. Derived from a traditional system, Generation Stair Tower has been enhanced to provide a system universally recognised and approved by sites and scaffolding contractors.

Using an economic 4 leg foot print, the tower is made up of composite components to fully support an integral staircase complete with non slip staircase treads and landings. All staircase units and landings are protected with double handrail frames. Fully galvanised and made of high quality steel, the tower is robust and hard wearing.

This guide relates only to the components used as a temporary site access staircase system and does not cover the use of system parts to create any other structure.

Erection of Staircases does not follow the normal sequence of access scaffolding and care must be taken in their erection. It will be necessary to create temporary working platforms and additional hand railing to efficiently and safely erect staircase towers. Erectors should work within the guidance of SG4 and should consider where appropriate the use of protection systems. This guide specifically relates to SG4 and its guidance is appropriate to normal scaffolding procedure developed entirely to meet the requirements of the Working at Height Regulations (WAHR) 2005. This user guide has been compiled to enable Collective Fall Prevention to be used whenever possible.

Fast:

Components can be fastened with simple locking mechanisms. Lighter with less components, systemised Modular construction ensures accuracy and speed.

Safe:

Fully complying with EN 12810 and EN 12811. Generation Stair Tower has been designed with safety in mind with all components complying to the current standards.

Easy to Erect:

By its modular design, Generation Stair Tower automatically sets standard spacing and lift heights so that levelling and plumbing of the scaffold is not required after the base lift.

Cost Effective:

Lighter weight, no loose fittings, fully galvanised, no ledger bracing, and reduced labour.

Compliance

Generation Stair Towers BS EN 12810 - BS EN 12811

Generation Stair Tower System as supplied by Generation UK Ltd trading as Generation Hire and Sale has complied with the structural requirements of BS EN 12811 with regard to the component and testing and calculation requirements.

Generation Stair Tower has been tested by an independent and nationally certified testing laboratory (UKAS No: 0955) and their reports (March 2009) are in accordance with the requirements of testing as required within BS EN 12810 and BS EN 12811.

They have certified that the calculations undertaken in support of the guidance enclosed within this user manual and supporting calculations have been undertaken in compliance with the requirements of BS EN 12811 and are suitable for use.

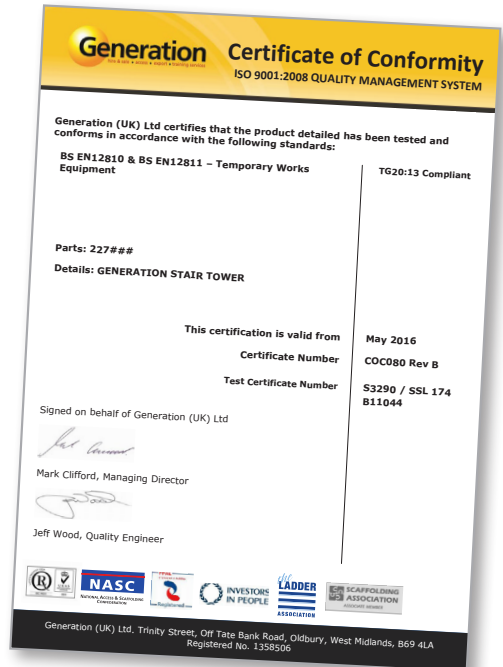

**NATIONAL ACCESS & SCAFFOLDING
CONFEDERATION**

NASC Code of Practice

Generation Stair Tower supplied by Generation UK Ltd has been audited by the NASC and has met the criteria to satisfy the NASC Code of Practice for proprietary System Scaffold Systems used as a staircase.

Generation Stair Tower has been independently tested and has met or exceeded the criteria for Quality, Technical Specification and Compliance to EN 12810 and EN 12811.

Stair Tower Basic Information

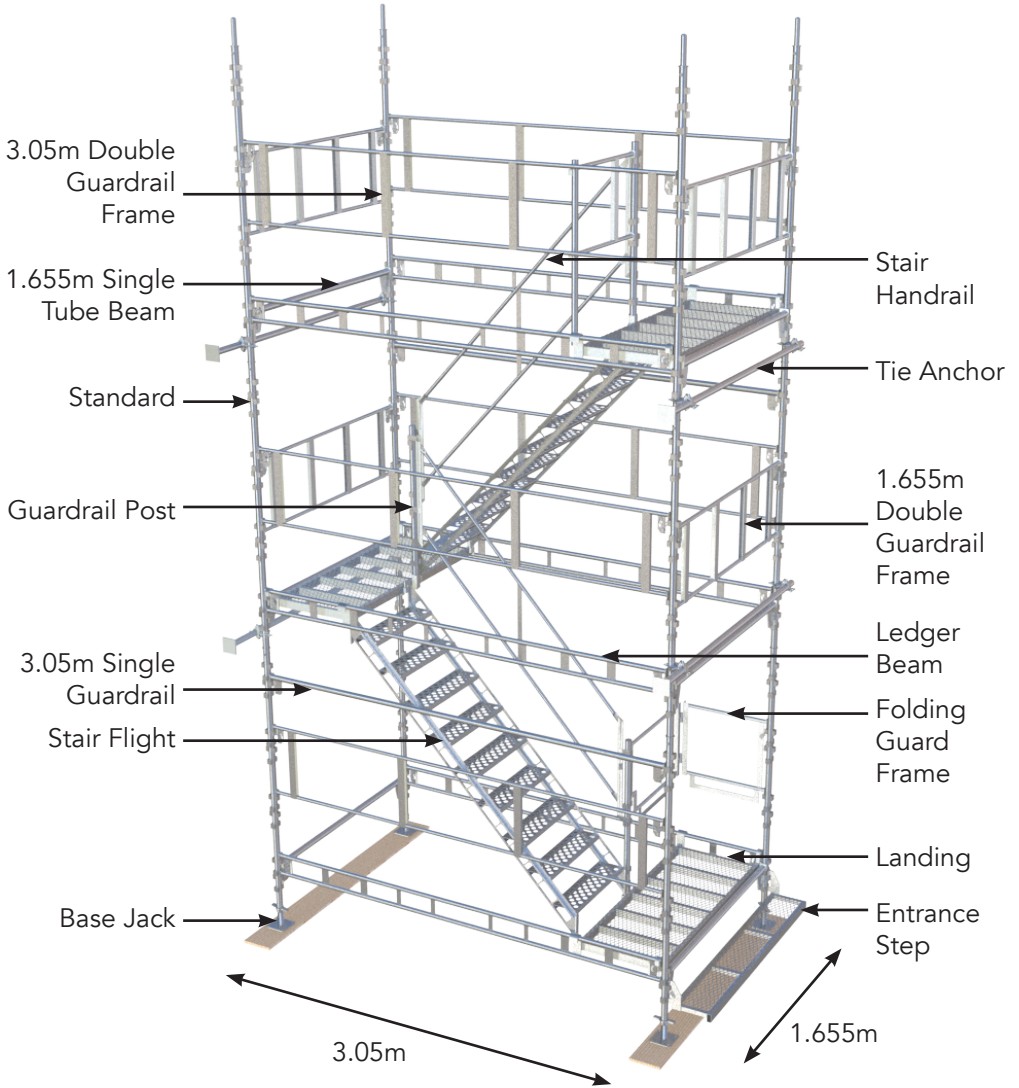

Stair Tower Erection Notes

Advanced Guardrail

To enable advanced guardrail to be fitted, there must always be a minimum of 1m of standard above the landing. Please refer to page 22 of this manual for leg make-ups.

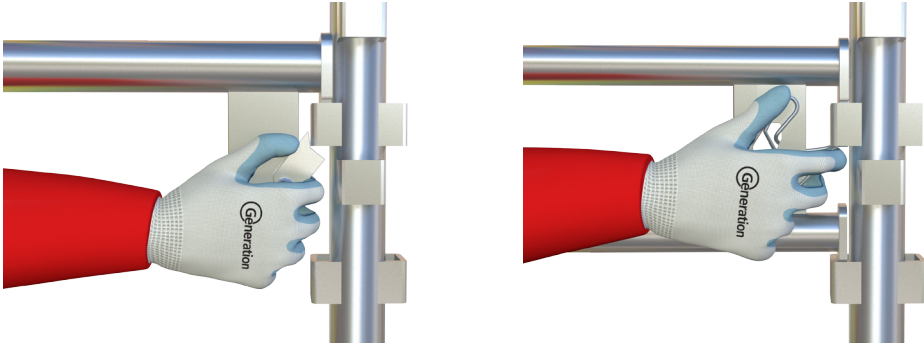

Always ensure all locking catches are engaged.

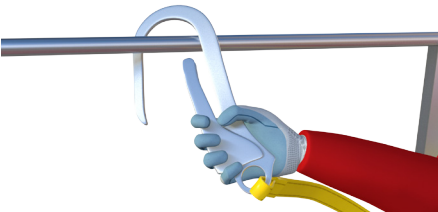

When outside of a guard railed area the erectors must clip-on.

- 1** A minimum of 2no trained competent erectors wearing work restraint twin tail lanyards of fixed length of 800mm (including fittings.)
- 2** Prior to erecting, determine the position of the tower and where access/egress points are required. Side access/egress points can only occur in a 2m lift.
- 3** Ensure ground conditions are capable of carrying imposed loads (both self weight and live loads.)
- 4** Timber sole boards should always be used. Refer to TG20.
- 5** Always start erecting with the stair flight on the left side for a clockwise direction of ascent.
- 6** Always use 2no 1.655m X 0.61m erection platforms and 1 set of advanced guardrail tools to aid erection.

Safety Information

Competent, appropriately trained persons should only erect the Generation Stair Tower. Generation UK's Training division can provide a one day training course for the Safe Assembly, Use and Inspection of the Generation Stair Tower. The syllabus for this course can be found on page 31.

Generation Stair Tower fully complies with the structural requirements of BS EN 12810. The guidance enclosed within this manual and supporting calculations have been undertaken in compliance with the requirements of BS EN 12811 and are suitable for use.

Operatives erecting Generation Stair Tower have a duty to work within the Health and Safety at Work Act 1974, Construction Regulations Safe Place of Work Act 1996 and the Work at Height Regulations 2005.

Erection of stair towers should always be undertaken using the most appropriate fall arrest or fall protection systems. At all times operatives should work safely and mindful of risk to themselves and others. Harnesses should be used at all times in line with current legislation, when erecting, dismantling and working on scaffolds, erection platforms should be installed from below and handrails should be installed during the erection process. Full protection using mesh landings and double hand railing should be installed for the protection of end users. Generation also recommend the use of collective fall protection methods.

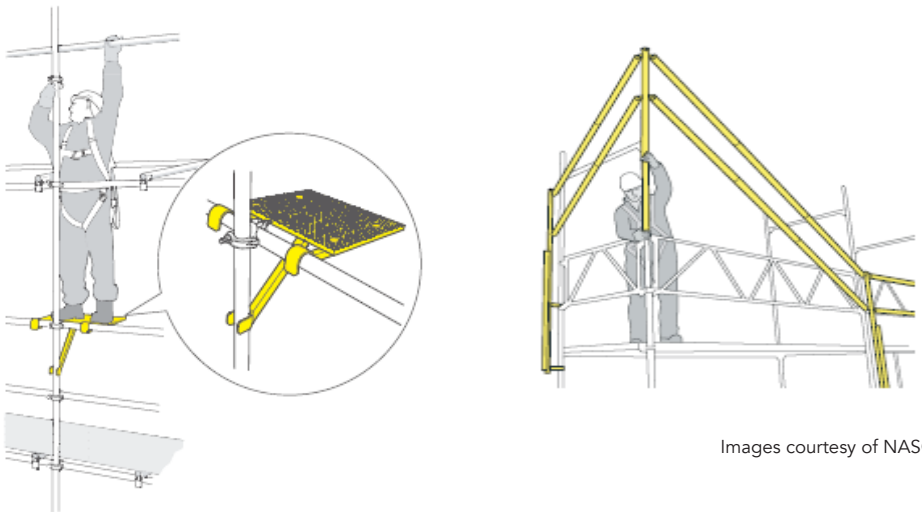

Images courtesy of NASC

This guide is designed for instruction of erectors who are already qualified to erect conventional scaffolding and work within the guidelines of SG4.

General Site Safety

All operatives erecting Generation Stair Tower have a duty of safety to themselves, others working on or near the scaffold and all persons who may be nearby.

- Before erection of any scaffold all ground and sub base must be inspected. The ground should be level and supported using sole boards
- Towers must be tied and adequately braced in line with the recommendations in this guide
- All working platforms require double handrails and toe boards. Generally, toe boards are not required on Staircase landing platforms, as they do not constitute a working platform. TG 20 states that "toe boards can be dispensed with" however, toe boards may be required as a result of a local risk assessment
- Additional protection such as debris netting, brick guards, sheeting and protection fans may be required. Any additional wind load will require advice from a temporary works designer
- Scaffolds should never be overloaded. Be aware of the maximum loads permitted on the specific scaffold
- Never add sheeting, hoarding or netting unless the structure has been specifically designed for that purpose
- Inspect all components before use for suitability and damage
- Scaffolds including Stair Towers are required to be inspected every seven days by the user and records kept
- Safe access and egress to and from the scaffold must be ensured using the most appropriate method

Important Notice:

To comply with latest health and safety rules and procedures you must use two temporary erection platforms.



Principal Components

The components noted below are specific to Generation Stair Tower and are designed for use within the Generation Stair Tower System.

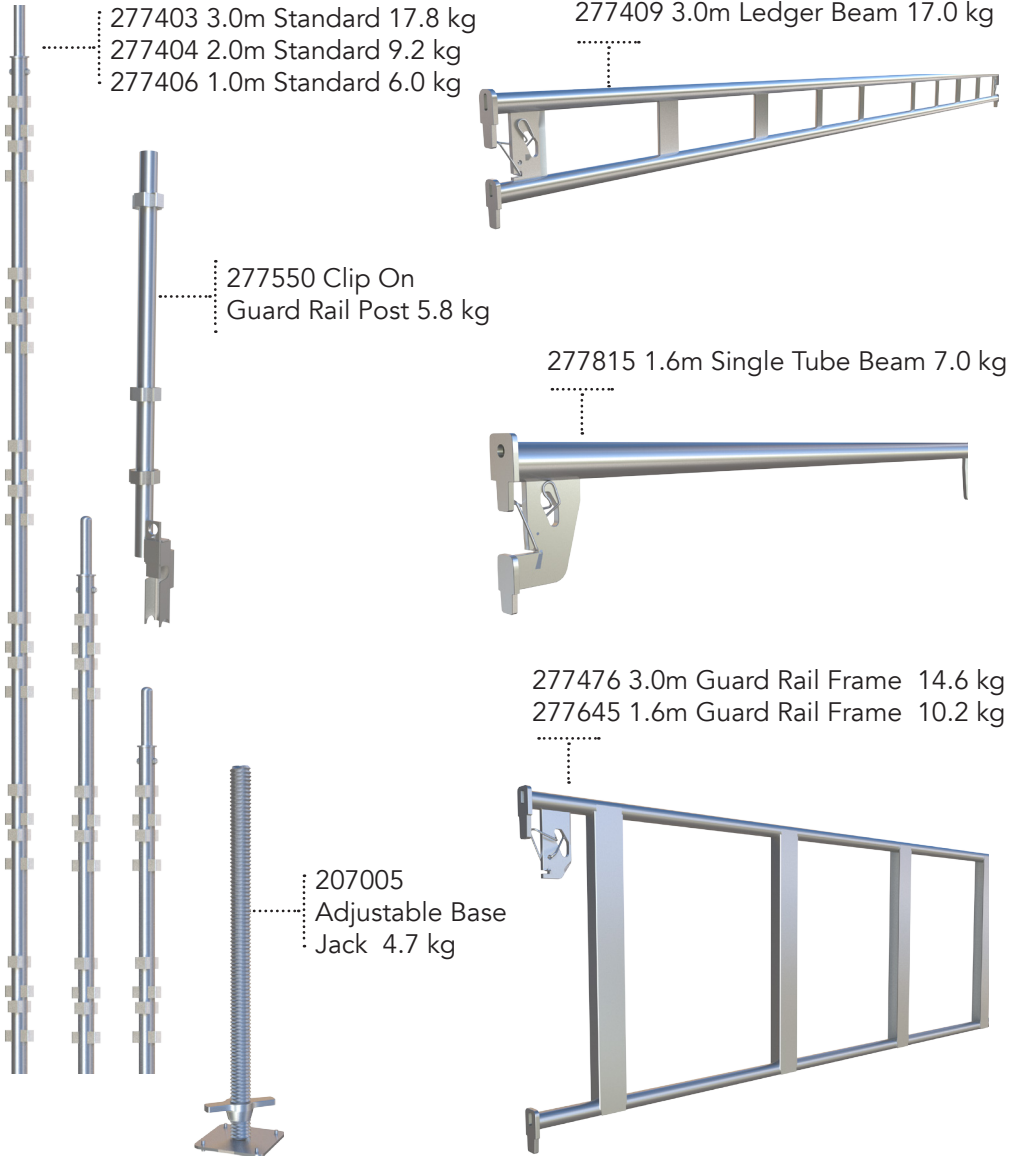

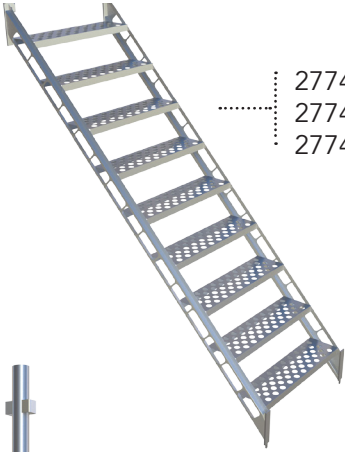

- 277427 2.0m Stair Flight 43.0 kg
- 277428 1.5m Stair Flight 33.5 kg
- 277425 1.0m Stair Flight 28.0 kg

- 277414 2.0m Stair Guard Rail 13.8 kg
- 277415 1.5m Stair Guard Rail 12.5 kg
- 277421 1.0m Stair Guard Rail 10.5 kg

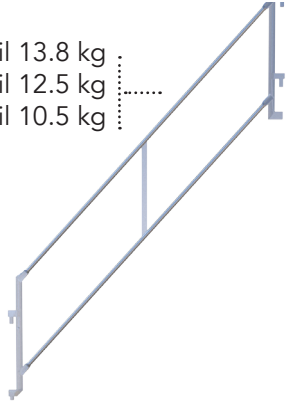

- 277477 Guard Rail Post 11.0 kg

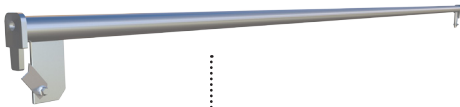

- 277418 3.0m Guard Rail (Single) 10.4 kg
- 277469 2.16m Guard Rail (for Exit Point) 8.0 kg

- 277479 Folding Guard Frame 9.2 kg

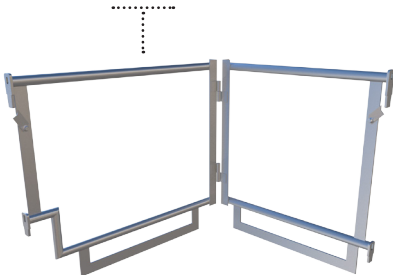

- 277478 Guard Rail Frame 9.2 kg

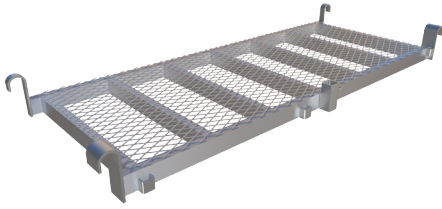

277432 Landing 27.7 kg

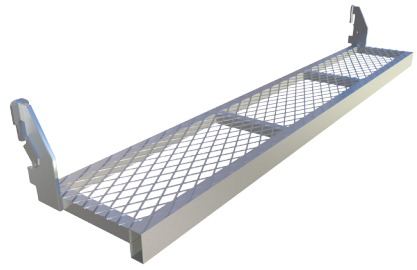

277426 Entrance Step 13.4 Kg

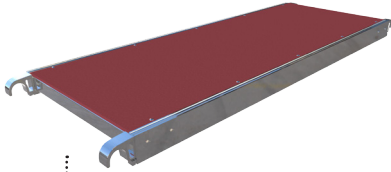

277480 Erection Platform 15.0 kg
two required to comply with safe
assembly procedure

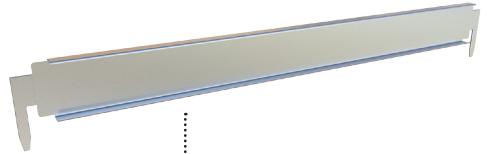

278121 End Toe Board 5.2 kg

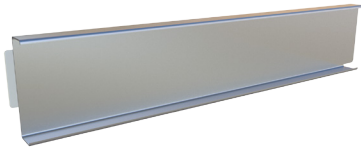

278123 Top Toe Board 3.2 kg

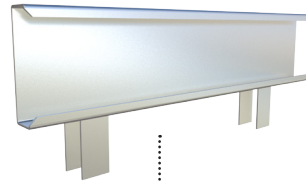

278122 Side Toe Board 3.0 kg



277433 Advance Guardrail
Tool 1.5 kg
Two required per tower

Stair Erection Sequence

Use advance Guardrail methods for Collective Fall Prevention wherever possible. Where Collective Fall Prevention is not possible, Work Restraint Methods are used. This method has been devised in line with the hierarchy of the work at Height regulations (WAHR 2005.)

Safety Harnesses and Lanyards should be clipped to the highest available horizontal member. Twin tail 800mm fixed length lanyards are recommended. The principle of the Advanced Guardrail System is that the structure is erected with guardrails placed in advance of the work in progress to provide collective protection at all times. This requires that the configuration of standards should always extend at least 1m above the proposed next working platform. Depending on the height of the tower, the standard make-up must be determined before commencement. For 2m lifts it is recommended that 4m (2m plus 2m) of standard are used at the base lift level (see page 22 Standard Leg Make-ups.) Temporary guardrails should be used in conjunction with erection platforms where there is a risk of fall. Harnesses and lanyards should always be used.

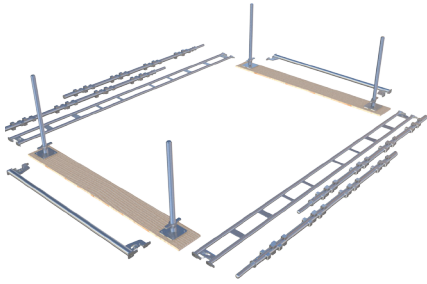

- 1** After inspection of ground condition, set out sole pads and base plates at position of standards. Make ready components for base lift. Adjust jacks roughly to estimated final height.

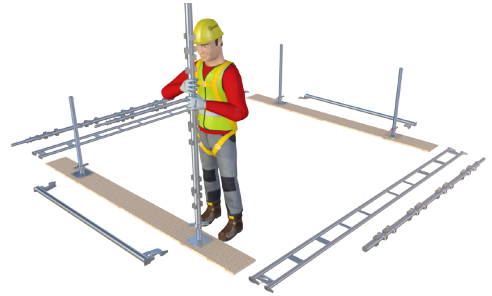

- 2** Place standard on a base jack. It is essential that pockets are running in direction as shown (low pocket 1.65m width wise direction and high pocket 3.05m length wise direction).



- 3** Connect 3.05m ledger beam to higher level pockets. Connect 1.65m single ledger beam to lower level pockets.

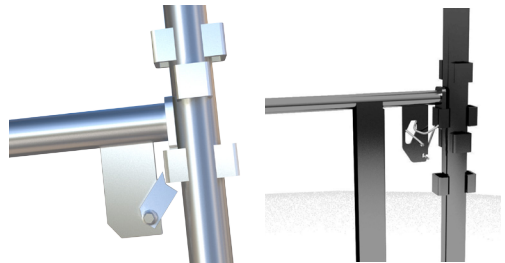

- 4** Engage all locking clips to secure connection as you proceed.

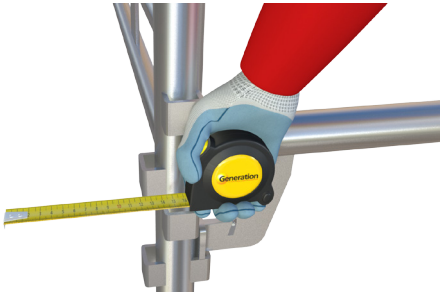

- 5 Check distance from structure or adjacent scaffold at both ends of the stair tower.



- 6 Use a spirit level to adjust the jacks as required following a clockwise direction.

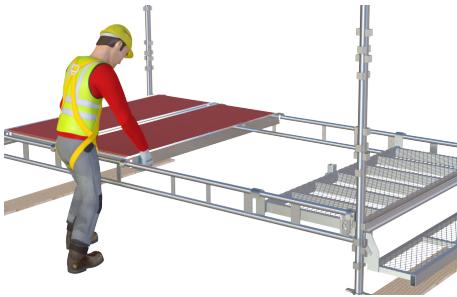

- 7 Install Entrance step, 2no. erection platforms and 1no. landing platform then check for square.

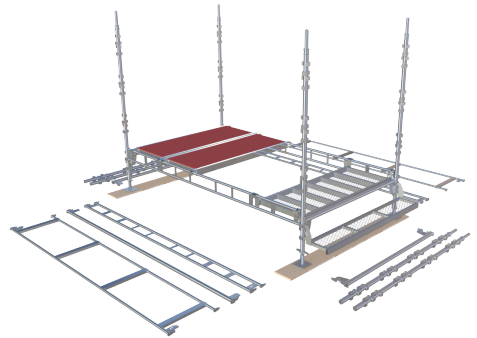

- 8 Select the appropriate equipment for next lift.

Collective fall prevention:

Working at height regulation requires that a hierarchy for work at height to be followed where collective fall prevention and protection measures should take priority over personal measures. Temporary working platforms with guardrails will take priority over personal fall protection. i.e. fall arrest systems.

Note:

If as part of your risk assessment you consider a fall from base level temporary or landing platforms could cause injury then temporary guard frame should be fitted to all sides to enable erectors to clip on with their lanyards.



- 9 If required by your local risk assessment, add 1m high temporary guardrails to base lift.

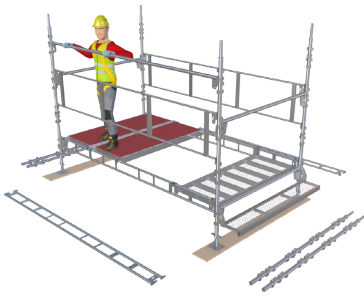

- 10** Fit 3.05m double guardrail frames and 1.5m high single guardrail and temporarily fit 1.65m ledgers at 1m lift level to enclose base lift.



- 11** Further standards are now added to ensure 1m guardrail frames can be fitted to next lift from below. Orientation of standard pockets must match the orientation of pockets below.



Where full enclosure to base lift is required by local risk assessment, then two further 1.65m ledgers will need to be added whilst keeping full enclosure to the base lift insitu.

- 12** Whilst using 3.05m guardrail frames to clip onto, move the 1.65m ledgers up to the required next lift level.

IMPORTANT NOTICE

Lanyards are not shown as it is the responsibility of operatives to ensure the correct use of fall arrest equipment. i.e. where to clip on. Whilst working outside of a fully enclosed guard railed area or exposed to a leading edge, operatives must be clipped on to the highest available horizontal point using 800mm fixed length twin tail lanyards.



Where full enclosure to base lift is not required by Local risk assessment then it is recommended that two 3.05m guardrail frames are used at base lift until the stair unit and folding guardrail frame are added.

- 13** To complete the Installation of the 2nd lift, add 3.05m ledgers at the required lift level.



- 14** Using the advance guardrail tool, 2 erectors should offer up the next guardrail frame to the 1m position above the next lift level.

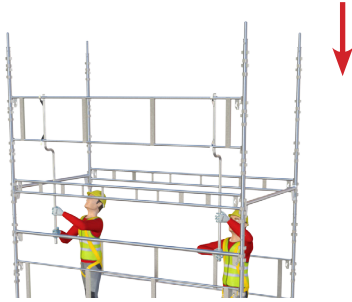

15 Locate tongues of the guardrail frame into the standard pockets and pull down to secure. Ensure all tongues are engaged.

Guardrail frames indicated are temporary to aid safe erection. These temporary guardrail frames can be moved up and reused further on in the erection procedure.

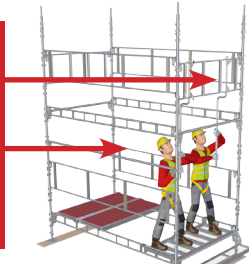

17 Add 1.65m and 3.05m guardrails to complete the collective protection above the next working level.



19 Stair unit is placed vertically into the pockets on the left side of the lower landing platform. Stair unit must be fitted in a clockwise ascent.

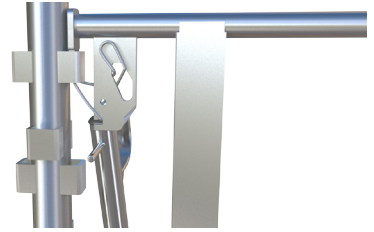

16 Using advanced guardrail tool, ensure locking device is engaged.

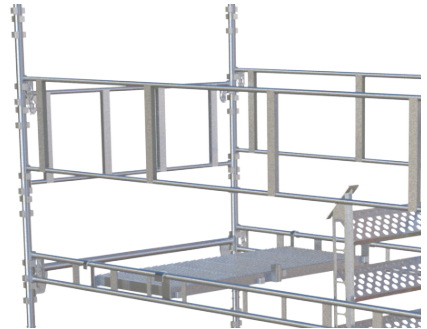

18 To prepare for the staircase, place landing platform and push forward.

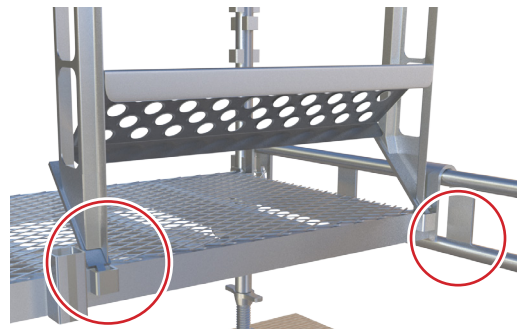

20 Ensure the staircase is properly located in the pockets. All subsequent lifts will require the operatives to clip on to the rear 1m high guardrail, using 800mm fixed length twin tail lanyards.



21 Stair flight is then lowered to meet the upper landing, pushing it into position.

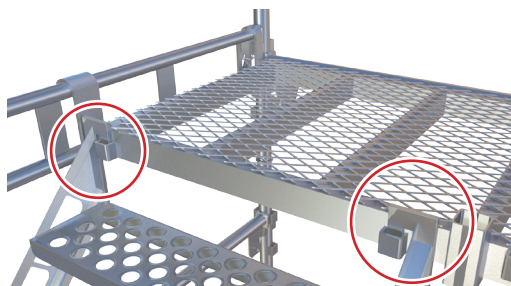

22 Ensure the stair flight is fully locked into position in the pockets of the upper landing.



23 Install guardrail posts to the upper and lower landing platforms.



24 Install stair handrail to guardrail posts ensuring that catches are fully secured.



25 Remove temporary 3.05m double guardrail frame and fit folding guardrail frame to protect lower landing.



26 Temporarily fit a top guard frame to protect upper landing platform. From the stairs this may be moved up as the stair tower progresses.

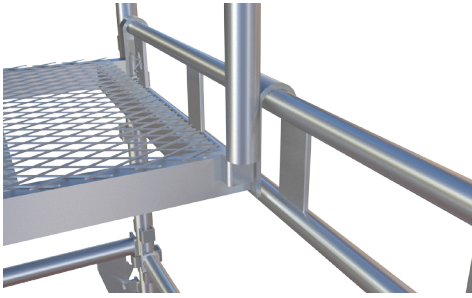

27 Once fitted the guard frame should be checked from the platform side. Ensure that the tongue is properly located in the landing pocket.



28 Tie the rear inner and outer standards, using tube and double right angle couplers, and then anchored back to the support structure.

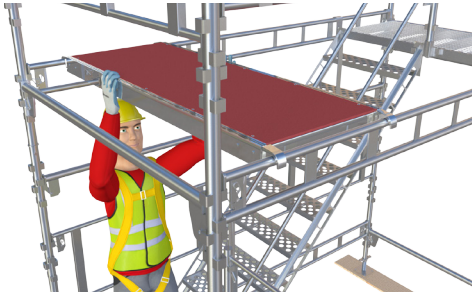

29 Re-position erection platforms to assist further progress. Ensure temporary guardrail is in place to erection platform level in use. This may be reused on subsequent lifts.

IMPORTANT NOTICE FOR STEP 30

Operative accessing temporary platforms from the stairs must be clipped on as shown in the sequence below.



30A



30B



30C



- 31** Further standards can be installed to gain extra height and ensure 1m high guardrail can be installed to next lift from below. Orientation of pockets on standards must be the same as orientation below.

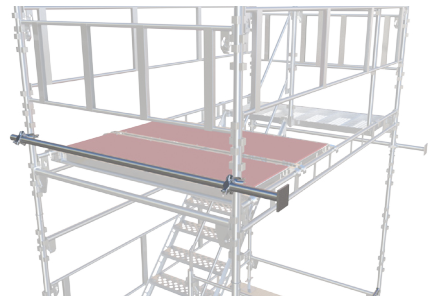

- 32** Install 2nd tie to front inner and outer standards, using tube and double right angle couplers, and then anchored back to the support structure.

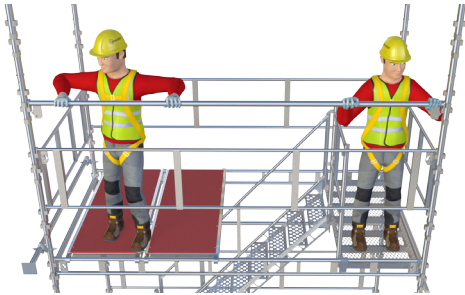

- 33** Install 3.05m single guardrail for 2m stair unit lifts at 1.5m lift level.



- 34** Carefully select and pass up all the equipment required for the installation of the next lift.



- 35** The sequence 12 to 34 is then repeated to achieve additional lifts, making sure to clip onto rear guardrail before removing the temporary top guard frame to install subsequent stair units.

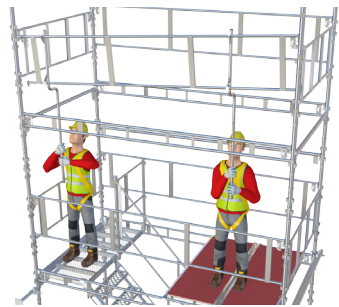

36 When tower has reached its overall height methods of access and egress are installed to top and intermediate lift levels as required.



37 Where top level side access is required, 3.05m guardrail frame is omitted and 1no. clip on post and two 2.16m single guardrails are installed from the stairs.



38 Where top level end access is required, the 1.65m guardrail frame is omitted. 3.05m guardrail frame is used to protect the sides of the landing platforms. The top guardrail is fitted from the staircase to protect the landing return.



39 For intermediate landing level end access, 1.65m guardrail frames are removed.

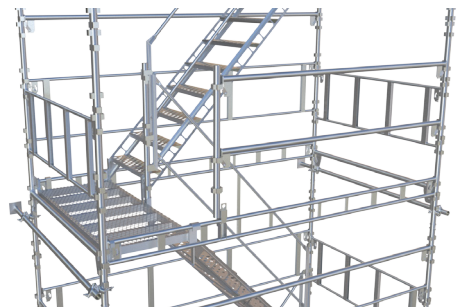

40 For intermediate landing level side access, 3.05m guardrail frame is omitted and 1no. clip on post and two 2.16m single guardrails are installed from the stairs.

Toe Board Arrangements

All working platforms require double handrails and toe boards. Generally, toe boards are not required on staircase landing platforms, as they do not constitute a working platform. TG 20:08 states that "toe boards can be dispensed with" however, toe boards may be required as a result of a local risk assessment.

Toe boards are not a mandatory requirement for use on Stair Towers where they do not constitute a working place. TG20:13 confirms that toe boards may be dispensed with on stairways. A risk assessment may define a requirement where there is a risk of falling material.

The end toe board tongues are fitted into the outside pockets of standards.

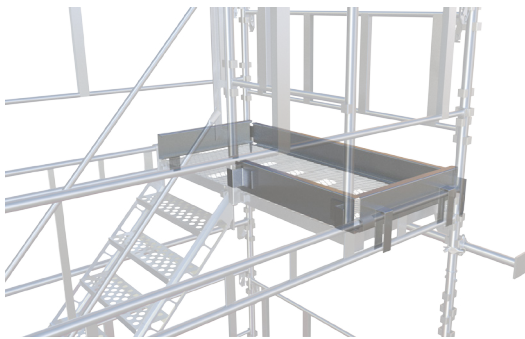
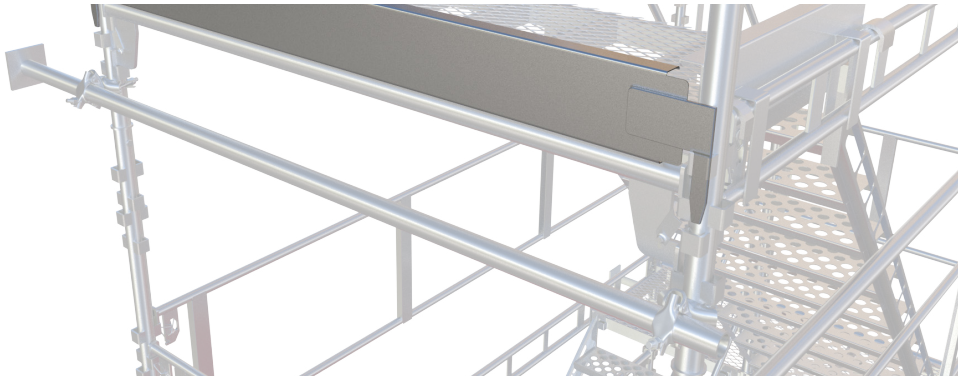

Locate top toe board tongue into pocket of guardrail post and the flange onto the guard frame.

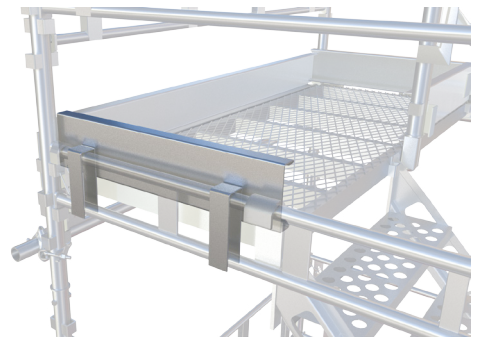

Side tow boards are located directly onto ledger beams.

Standard Leg Make-ups

Key:

- Lift height
- Standard height

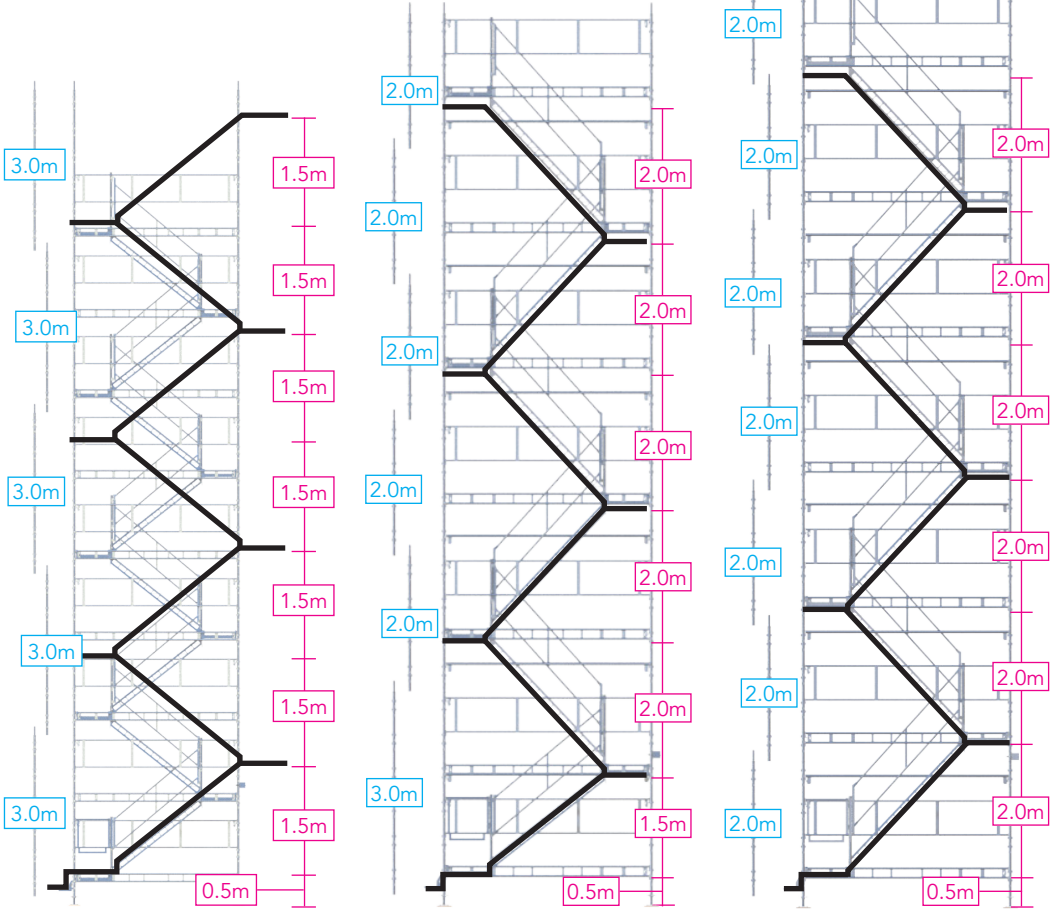

Leg make-ups for 1.5m standard lifts, using 3m standards.

Leg make-ups for 1.5m base followed by 2.0m standard lifts. Common arrangement for access and egress at 2.0m lift heights.

Leg make-ups for 2.0m standard lifts using initial 4m (2m+2m) standards to allow advance guardrail for second lift. (See erection sequence)

Repair and Maintenance

Generation Stair Tower is manufactured from high quality steel and hot dipped galvanised both inside and out for full protection. It has a high resistance to damage and is designed in such a way that components are extremely resilient in normal use. All ends of horizontal and locking components are designed with minimum protrusions. Ledger beam horizontal members are fitted at each end with easy maintenance locking devices. Adjustable jacks are manufactured with self-cleaning threads.

In use, however anyone who handles scaffolding components has a duty of care to ensure that they are fit for purpose.

- Material must be inspected before each delivery
- Erectors must inspect components before erection
- Damage of any sort must be identified and the item quarantined
- Damaged equipment should be returned to a competent repairer

Inspection of the Generation Stair Tower will include:

- All moving components rotate or slide freely
- All welds are free of cracks
- Visual inspection for corrosion
- Inspection for mortar and surface debris
- Sight along length for bending
- Ledger ends for distortion
- Standards free of internal debris
- Jacks free to rotate on all thread
- Missing components such as locking devices
- Negligent or damage by abuse

Any equipment found to be damaged, cut, misaligned or seized should not be used, quarantined and be returned to a holding area for inspection by a competent repairer. In the event of any doubt, contact a Generation Hire & Sale representative who will be pleased to advise.

Dismantling of Generation Stair Tower

It is essential that the sequence for dismantling is the same process as for erection in reverse. Care must be taken to ensure that the same safety precautions are applied at all stages of the dismantle. Restraint and protective measures should be used at all times (see page 9). Before dismantling takes place, the structure should be inspected for correct erection and identification where adaption or alteration may have been undertaken. Erection of temporary platforms should be installed along with temporary handrails during the dismantle.

Safe Working Loads

Generation Stair Tower is built from modular components and tied back to a supporting structure (e.g. a building or scaffold) at every lift. It is assumed that this supporting structure is inherently stable and capable of providing a stable platform for supporting the stair with respect to horizontal restraint. The order of design is generally as follows:

- Components are checked for accommodating the required code value of 1 kN/m² imposed loads, with 2 kN/m² and the maximum safe working loads also considered
- The tower is analysed up to 30m for the 'In Service' condition as required by BS EN 12811
- The tower is analysed up to 30m for the 'Out of Service' condition as required by BS EN 12811

LONG FACE PARALLEL TO BUILDING

Tower height (M)	Max. no. personell
2	
4	
6	
8	22
10	27
12	32
14	37
16	42
18	47
20	52
22	57
24	62
26	67
28	72
30	77
32	81
34	86
36	91
38	95
40	92
42	90
44	87
46	85
48	83
50	81

Allows for gravity loads only - lateral forces must be considered. For the purpose of the table 1 person = 1kN

SHORT FACE PARALLEL TO BUILDING

Tower height (M)	Max. no. personell
2	
4	
6	
8	22
10	27
12	32
14	37
16	42
18	47
20	52
22	57
24	62
26	65
28	63
30	61
32	58
34	56
36	54
38	51
40	49
42	47
44	44
46	42
48	40
50	38

Allows for gravity loads only - lateral forces must be considered. For the purpose of the table 1 person = 1kN

Platform Elements

UDL of 1.0kN/m² or a point load of 1.5kN. An additional check at 2.0 kN/m² is also carried out, with the maximum safe working load of the component under certain load locations also derived.

Guardrail Elements

Downward load - 1.25kN point load in the most onerous position. Treated as an accidental load. Horizontal load - 0.3kN point load over an area of 0.3x0.3m. 0.15kN on toe boards only.

Standards

Axial capacity at L=2.0m

35.27 kN (Long Face Parallel) Tied every leg every lift

24.48 kN (Short Face Parallel) Wing braced both sides at every lift

Moment Capacity = 1.4 kN.m

Maximum Heights

Maximum Heights and Tying-in Pattern Requirements

The maximum height to which a Generation Stair Tower may be erected is dependent upon a number of factors, the most important of which are:

1. The vertical and horizontal distances between tied points on a standard
2. The lift height
3. Wind loading
4. The Vertical loadings in the legs due to self-weight and the Working Platform Loading
5. Whether or not the cantilever platforms are used
6. Whether or not the foot ties are used
7. The inclusion of Debris Netting or Sheeting to the Scaffold

The parameters detailed in this manual are based on calculations and the results of testing for Generation Stair Tower only.

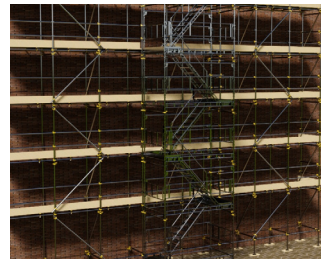

LONG FACE PARALLEL TO BUILDING

S	Maximum Tower Height (m)	
Value to be ascertained subject to site	In Country	In Town
20	30	30
24	30	30
28	30	30
32	20	22
36	10	14
40	6	8
Derived from Out of Service Condition - In Service acceptable to 30m		

SHORT FACE PARALLEL TO BUILDING

S	MAXIMUM TOWER HEIGHT (M)	
Value to be ascertained subject to site	In Country	In Town
20	30	30
24	30	30
28	30	30
32	30	30
36	30	30
40	30	30
Derived from Out of Service Condition - In Service acceptable to 30m		

This User Guide utilises wind loading in the preparation of its safe working height tables for access scaffolds. These tables are limited to "S" values above 20 and below 40. Where localised conditions result in "S" values outside of these parameters the wind velocity pressures will either be lower than or exceed those utilised within the calculations from which the tables are derived. Scaffolds located to the edges of cliffs or escarpments, in coastal locations or to tall structures surrounded by other tall structures which may cause funneling of the wind pressure are all susceptible to significant increases in wind pressure due to local effects. In these instances, it is recommended that advice is sought from the Technical Services Department.

The safe height tables and section capacities contained within the User Guide are based upon live loading from the intended use only. Additional loading may accrue on the working platforms or components as a consequence of atmospheric precipitations such as ice, snow, sand or dust. The working processes may also cause debris such as sand, grit or demolition debris to accumulate on the working platform of components which will increase the live loading above that allowed for within the live loading.

Where this is seen to occur or is known to occur, further guidance should be sought from the Generation UK Ltd Technical Services Department which may result in down grading of the Load Class for the scaffold.

Ground Condition

The foundations for a scaffold should be adequate to carry and disperse the load imposed both locally at each standard and, in general, to carry the whole weight of the scaffold. The responsibility for the adequacy of the foundations should be established and approved prior to erection. The client for the scaffold and/or the contractor may need to be consulted. The foundation for a scaffold should be maintained in an adequate condition during the life of the scaffold. Regular inspection procedures must be provided and use suspended if there is found to be any loss of support.

Bracing and Tying In

The tower should be tied to existing structure at each lift (i.e. 2m vertical centres) using horizontal ties at each side that securely fix to the existing structure and to the inner and outer standard.

Where the tower has the short parallel to the existing structure, additional ties should be provided at each lift from the outer standards at 45 degrees back to the existing structure. These additional ties are to be securely fixed to the existing structure and the fixing is assumed to be capable of resisting horizontal forces both parallel and perpendicular to the plane of the wall and are to be fixed within 300mm of the platforms ledge beam.

The tower is assumed to be unclad and free from netting and sheeting, such that the only area presented to the wind is that of the components of the tower.

Tie Components

Additional components outside the systems standard component set may be required to enable use in accordance with this User Guide. These will normally constitute loose tubes to EN39 and fittings to EN74.

Bracing

Provided the tower is erected and tied to the structure or existing scaffolding in the manner described in this guide, it is not generally necessary to brace the face and side elevations of the tower. Where structure is not available or ties have to be omitted at the lift heights, a scaffold bracing system should be used to provide a tie to the lift back to a position of effective restraint or the Generation (UK) Ltd Technical Service Department contacted for advice. Bracing appropriate to Generation Stair is available from Generation Hire and Sale branches nationwide.

Crane Handling of Towers

For the relocation of Generation Stair Tower at different areas of the site and to save dismantle and re-erection time, it is possible to crane handle individual erected Towers. However the following guidance is recommended:

- It is essential that the proposed new position is adequately prepared in advance of lifting operation and that appropriate sole plates are set out and levelled on suitably prepared ground ensuring there is only minimal requirement to use jacks to line and level the full structure once set in place
- It should be established that the crane weight capacity and reach is sufficient to lift the staircase safely. Weights of individual towers can be gained from Generation Hire and Sale
- All loose components should be secured and splices installed on all normal gravity spigot type joints. These will predominantly be the standard joints and the use of 4mm tube splices with 4no EN74 A swivel couplers, 2no each side of the joint, to each joint would be sufficient. Adjustable bases should be wired and secured to prevent loss when lifted
- To keep the tower rigid, plan bracing is required at the base of the tower, immediately under the top platform, and at 4m intervals of the tower height. Plan Bracing should be of 4mm tube to EN39 with EN74 B Double Couplers
- Lifting spreaders should be used. All lifting apparatus should be fixed to the standards only, not the ledger beams. Forces to the standards should be concentric to their length so as not to impose lateral forces on the standards. The use of scaffold tubes attached as described above with right angled couplers at the lifting points will prevent this if a lifting frame is not available
- If there is any doubt a Temporary Works Designer or the Technical Department should be contacted
- The Stair Tower system is designed predominantly for use as a compression system and should only be considered for use in top hung applications with input from the Technical Services Department or a suitably experienced temporary works engineer
- In a top hung application all components will continue to be effective in their normal mode of use and capacities with the exception of the standards. The standards would require tension splices to be designed and detailed at each spigot position throughout the tower with the use of tubes to EN39 and scaffold fittings to EN74

Rescue Plan

Generation Stair Tower is a fast and simple system which when erected by suitably trained and skilled operatives improves levels of safety over traditional methods. Automatic positioning of all components including handrails without the need for levelling ensures safety whilst erecting. The system with handleable components is easily erected safely and efficiently.

However, erectors need to be mindful of the risks and plan to work as safely as possible. In accordance with the Fall from Heights Regulations 2005 (as amended), every attempt should be made to “mitigate the risk involved by prevention of falls by using work equipment or other measures to prevent fall. Where they cannot avoid working at height and where they cannot eliminate the risk of a fall, use work equipment or other measures to minimise the distance and consequences if a fall should occur”.

Generation recommends the use of collective measures such as Advanced Guardrail systems, Hop-Ups and Steps where structural parts and handrails can be installed from a place of safety during the erection process. Alternatively, use fall protection equipment to restrain and limit any falls. Harnesses should be worn and used at all stages of erection of The Generation Stair.

The “Work at Height Regulations 2005” specifically requires every employer to take account of the need for an easy and timely evacuation in the event of an emergency where scaffolders or operatives suffer disability or falls when suspended in a harness.

A site specific Risk Assessment and Method Statement is essential in determining the plan required for the recovery of a disabled or incapacitated person. Generation recommend that contractors and employers develop their own rescue plan in accordance with the recommendations of the NASC in their documents SG4 and Guide to Formulating a Rescue Plan SG19.

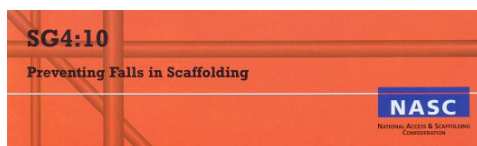

All erectors should be trained in the use of special rescue equipment and ensure all equipment for rescue is available and is fit for use at all times.

NB: Legislation is consistently being updated and users are responsible to ensure that the latest and most appropriate is used at the time.

Training Services

Training Services

PASMA

CISRS

CITB

IPAF

The Ladder Association

NPORS

Other Courses

Freephone: 0800 587 5224

Visit: www.generationtraining.co.uk

Email: training@generationuk.co.uk



Generation Stair Tower Training

Duration:	One Day
Target Group:	Any person(s) who, as part of their working duties are required to erect and dismantle or inspect The Generation Stair Tower.
Aims:	The aim of the training is to provide candidates with the necessary information in the safe assembly, use, alteration and dismantling of The Generation Stair Tower.
Objectives:	At the end of the instruction the candidates will be able to: <ul style="list-style-type: none">• Have an understanding of the statutory regulations• Identify and quantify components• Erect and dismantle The Generation Stair Tower• Inspect a Generation Stair Tower
Course Content:	<ul style="list-style-type: none">• Health and Safety legislation and regulations• What is a Generation Stair Tower?• Generation Stair Tower components• Estimating quantities• Understanding drawings• Stair Tower erection, alteration, and dismantling exercises• Inspection report procedure• Manufacturers Instruction Manual• Multiple choice test paper
Safety Requirements:	As the instruction is carried out on site, the client's site regulations/requirements must be adhered to. PPE must be worn at all times throughout the instruction.

For further details on this or any other training course contact Generation Training Services on

0800 587 5224

training@generationuk.co.uk

Birmingham

Trinity Street Off Tat Bank Road, Oldbury
West Midlands B69 4LA

T: 0121 544 3355 F: 0121 544 3131

E: birmingham@generationuk.co.uk

Bristol

Unit 7, 12-16 Foundry Lane, Fishponds,
Bristol BS5 7UE

T: 0117 972 4550 F: 0117 972 4502

E: bristol@generationuk.co.uk

Cardiff

Martin Road, Tremorfa Industrial Estate
Cardiff CF24 5SD

T: 029 2046 3835 F: 029 2046 3246

E: cardiff@generationuk.co.uk

East London

Unit H, Hangman's Wood Ind Park, Stifford
Road, South Ockendon, Essex RM15 6RL

T: 020 7473 6056 F: 01708 858 493

E: london@generationuk.co.uk

Edinburgh

4 Westerton Road,
East Mains Industrial Estate,
Bloxburn, West Lothian EH52 5AU

T: 01506 863 864 F: 01506 863 916

E: edinburgh@generationuk.co.uk

Frimley

22-30 Sturt Road, Frimley Green
Camberley GU16 6HY

T: 01252 838 696 F: 01252 837 614

E: frimley@generationuk.co.uk

Glasgow

Duchess Road, Rutherglen
Glasgow G73 1AU

T: 0141 647 6969 F: 0141 647 5851

E: glasgow@generationuk.co.uk

Leeds

Unit 2 Ledger Park, Haigh Park Road,
Stourton, Leeds LS10 1RT

T: 0113 277 8822 F: 0113 277 7545

E: leeds@generationuk.co.uk

Newcastle

Forward House, Portobello Road
Portobello Industrial Estate, Birtley,
Tyne and Wear DH3 2SN

T: 0191 492 1190 F: 0191 411 1148

E: newcastle@generationuk.co.uk

Hire and Sale Branches Freephone:

0800 783 8376

Northampton

Kingsfield Way, Dallington,
Northampton NN5 7QN

T: 01604 580 444 F: 01604 580 487

E: northampton@generationuk.co.uk

Stockport

Unit 4 Vauxhall Industrial Estate, Greg Street,
Reddish, Stockport SK5 7BR

T: 0161 477 0131 F: 0161 477 7618

E: stockport@generationuk.co.uk

Specialist Light Access Branches

West Thurrock (East London)

4 Riverside Industrial Park, Oliver Road,
West Thurrock RM20 3ED

T: 020 7476 4760 F: 020 7476 3157

E: westthurrock@generationuk.co.uk

West Drayton (West London)

Unit 8, Horton Industrial Estate, Off Horton
Road, West Drayton, Middlesex UB7 8JL

T: 01895 430 630 F: 01895 430 434

E: westdrayton@generationuk.co.uk

Training Services

Freephone: 0800 587 5224

www.generationtraining.co.uk

Generation Training

Unit 20B Greens Industrial Park,
Calder Vale Road, Wakefield WF1 5PH

T: 01924 370 640 F: 01924 377 530

E: training@generationuk.co.uk

Generation Export

T: +44 (0) 121 543 2964

www.generationexport.co.uk

E: export@generationuk.co.uk

Head Office

Generation UK Head Office

Trinity Street, Off Tat Bank Road
Oldbury, West Midlands, B69 4LA

T: 0121 543 2950 F: 0121 543 2953

E: sales@generationuk.co.uk